

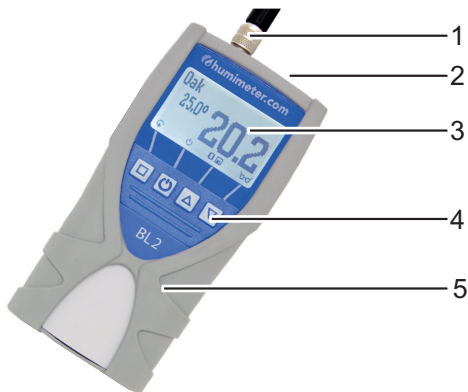

## Your humimeter BL2 at a glance

### The main unit



No.	Name
1	Connector for external sensor
2	USB port (optional)
3	Display
4	Keypad
5	Rubber protection cover

### Rear of the main unit

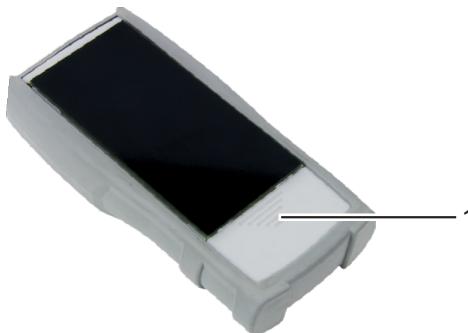

No.	Name
1	Battery compartment

---

## Overview external sensors

### Art.No. 12518 Insertion probe for wood chips

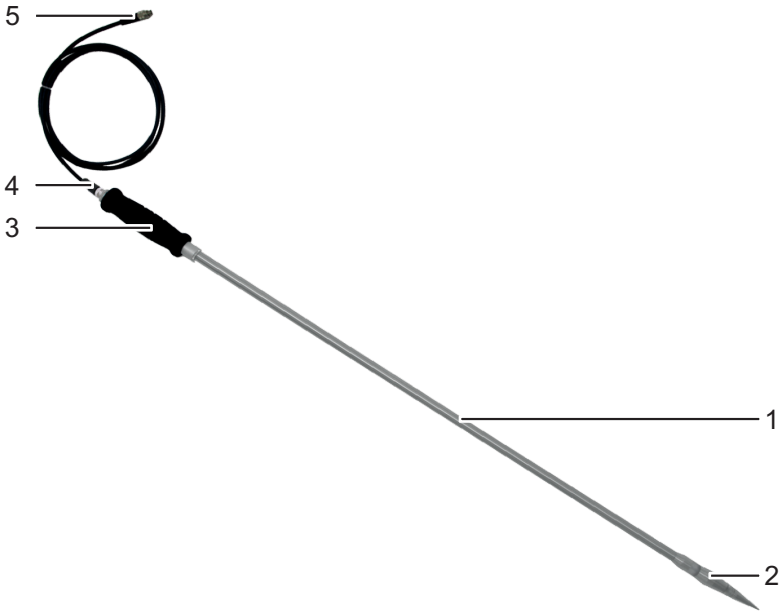

No.	Name
1	Insertion probe
2	Measuring head
3	Handle
4	Sensor connector
5	Device connector

Measurement:	Measuring range	Resolution
moisture content:	see " <a href="#">6.2 Calibration curves of the insertion probe</a> "	0.5 %
temperature °C:	-10 °C to +80 °C	0.5 °C
temperature °F:	14 °F to 176 °F	0.9 °F

Art.No. 12520 ram electrode



No.	Name
1	Metal handle
2	Measuring tips
3	Sensor connector
4	Device connector

Measurement	Measuring range	Resolution
moisture content:	8 % to 60 %	0.1 %
temperature °C:	-10 °C to +60 °C	0.5 °C
temperature °F:	14 °F to 140 °F	0.9 °F

Art.no. 12521 Set of tips for measuring hay and straw bales (for use with ram electrode)



## The display

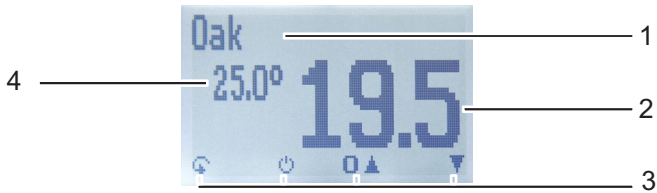

No.	Name
1	Calibration curve
2	Moisture content in % (" <a href="#">6.4 How moisture is defined</a> ")
3	Display symbols
4	Temperature display

## The display symbols

Symbol	Name
	Enter
	Up
	Down
	Back
	Enter numbers
	Enter letters
	Continue / go right
	Left
	Yes

Symbol	Name
	No
	Change input level
	OK
	Change menu
	Enter data
	View measurements
	Delete measurements
	On/off button, display light
	Save measured value

## The menus

The device has three different menus: Data Log, product selection and main menu:

### Product selection menu

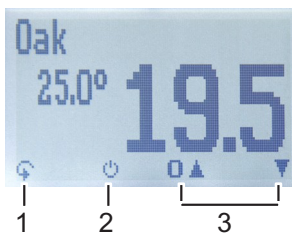

No.	Name
1	Change menu
2	Display illumination / device on/off
3	For changing the calibration curve

### Data Log menu



No.	Name
1	Change menu
2	Display illumination / device on/off
3	Save measured value
4	Show the last recorded values

---

## Main menu

The main menu comprises the following menu items:

- **Edit Logs:**  
Manual Logs, Clear Logs
- **Print Logs:**  
Last Log, All Logs, Clear Logs
- **Send Logs:**  
Manual Logs, Clear Logs
- **Options:**  
Bluetooth, Date/Time, Log Time, Language, Unlock, °C/°F, BL On Time, Auto Off Time, Materialcalibration, Password, Reset
- **Status**

## Table of contents

<b>Your humimeter BL2 at a glance.....</b>	<b>2</b>
The main unit.....	2
Rear of the main unit .....	2
Overview external sensors.....	3
The display symbols.....	5
The menus .....	6
<b>1. Introduction.....</b>	<b>12</b>
1.1 Information about this operating manual .....	12
1.2 Limitation of liability.....	12
1.3 Symbols used in this manual .....	13
1.4 Customer service .....	13
<b>2. For your safety.....</b>	<b>14</b>
2.1 Proper use .....	14
2.2 Improper use .....	14
2.3 User qualifications .....	14
2.4 General safety information .....	14
2.5 Warranty .....	15
2.6 Packaging .....	15
<b>3. On receipt of your device .....</b>	<b>16</b>
3.1 Taking the device out of its packaging .....	16
3.2 Making sure that all of the components have been included .....	16
3.3 Inserting batteries .....	17
<b>4. Using the device - Basics .....</b>	<b>17</b>
4.1 Switching the device on.....	17
4.2 Selecting the calibration curve.....	18
4.3 Connecting the cable to the sensor.....	18
4.4 Connecting the sensor to the device .....	18

---

4.5	Inserting the measuring tips.....	19
4.6	Taking a measurement .....	19
4.7	Switching the device off .....	19
<b>5.</b>	<b>The measuring process .....</b>	<b>20</b>
5.1	The measuring process with the insertion probe .....	20
5.1.1	Preparing a measurement .....	20
5.1.2	Taking a measurement .....	20
5.2	The measuring process with the ram electrode .....	21
5.2.1	Preparing a measurement .....	21
5.2.2	Taking a measurement .....	22
5.3	Hold function - Freezing the displayed value .....	23
5.3.1	Activating the Hold function in the Options menu .....	23
5.3.2	Using the Hold function .....	24
5.4	Saving individual readings .....	24
5.4.1	Activating the manual save function in the options menu.....	24
5.4.2	Using the manual save option.....	25
5.5	Saving several readings (a measurement series) at the same time .....	26
5.6	Viewing individual readings .....	28
5.7	Viewing individual readings from a series of measurements .....	28
5.8	Deleting all measured values (data log) .....	29
5.9	Deleting individual measurement series .....	29
5.10	Deleting single values from a series of measurements .....	30
<b>6.</b>	<b>Calibration curves .....</b>	<b>31</b>
6.1	Calibration curves of the ram electrode.....	31
6.2	Calibration curves of the insertion probe.....	32
6.2.1	Definition wood chip types (in accordance with EN ISO 17225-1).....	32
6.3	Selection of calibration curve for wood chips.....	33
6.3.1	Wood chips .....	33
6.3.2	Coarse wood chips.....	33

---

---

6.3.3	Industrial wood chips .....	33
6.3.4	Compression of wood chips.....	37
6.4	How moisture is defined.....	37
6.5	Definition of wood moisture .....	37
6.6	Notes for comparative measurement with oven-drying method .....	38
<b>7.</b>	<b>Using the LogMemorizer program .....</b>	<b>39</b>
7.1	Installing/opening the program .....	39
7.2	Exporting measured values to a computer .....	40
<b>8.</b>	<b>Checking on the device's status .....</b>	<b>42</b>
<b>9.</b>	<b>Configuring the device .....</b>	<b>43</b>
9.1	Turning on Bluetooth .....	43
9.2	Adjusting the date/time.....	43
9.3	Selecting a language.....	44
9.4	Activating options .....	44
9.5	Deactivating options .....	45
9.6	Selecting °C/°F.....	45
9.7	Reducing the device's power consumption .....	45
9.7.1	Configuring the display illumination time .....	45
9.7.2	Configuring automatic switch-off .....	46
9.8	Configuring the material calibration function.....	47
9.9	Changing the password .....	47
9.10	Resetting the device to its factory settings.....	48
<b>10.</b>	<b>Cleaning and maintenance.....</b>	<b>48</b>
10.1	Changing the batteries.....	48
10.2	Checking the calibration .....	49
10.3	Care instructions .....	50
10.4	Cleaning the device.....	50
<b>11.</b>	<b>Faults .....</b>	<b>51</b>

---

<b>12.</b>	<b>Accessories .....</b>	<b>53</b>
12.1	BL2 tube extension .....	53
12.1.1	Overview tube extension and humimeterBL2 .....	53
12.1.2	Demounting of the measuring tip .....	54
12.1.4	Installation of the extension .....	54
12.1.5	Tip assembly .....	55
12.1.6	Function test .....	55
12.2	Changing the measuring head (tip) .....	55
<b>13.</b>	<b>Storage and disposal .....</b>	<b>56</b>
13.1	Storing the device .....	56
13.2	Disposing of the device .....	56
<b>14.</b>	<b>Device information .....</b>	<b>57</b>
14.1	EC declaration of conformity .....	57
14.2	Technical data .....	61
<b>15.</b>	<b>Notes .....</b>	<b>62</b>

## 1. Introduction

### 1.1 Information about this operating manual

This operating manual is designed to enable you to use the humimeter BL2 safely and effectively. It is part of the device, has to be stored nearby and must be easily accessible to users at all times.

All users are required to carefully read and make sure that they have understood this operating manual before using the humimeter BL2. All of the safety and operating instructions detailed in this manual have to be observed to ensure the safety of the device.

### 1.2 Limitation of liability

All of the information and instructions provided in this operating manual have been compiled on the basis of the current standards and regulations, the state of the art, and the extensive expertise and experience of Schaller Messtechnik GmbH.

Schaller Messtechnik GmbH does not accept any liability for damage associated with the following, which also voids the warranty:

- Non-observance of this operating manual
- Improper use
- Inadequately qualified users
- Unauthorised modifications
- Technical changes
- Use of unapproved spare parts

This fast measuring procedure can be affected by a range of different factors. For this reason, we recommend periodically checking the device's measurements with a standardised oven-drying method.

We, as the manufacturer, do not accept any liability for any incorrect measurements and associated consequential damage.

---

### 1.3 Symbols used in this manual

All of the safety information provided in this manual is shown with a corresponding symbol.



#### **WARNING**

It is essential to observe this warning. Non-compliance can lead to serious irreversible or fatal injury.



#### **CAUTION**

It is essential to observe this warning. Non-compliance can lead to injury.



#### **ATTENTION**

It is essential to observe this warning. Non-compliance can lead to damage to property or equipment.



#### **Information**

This symbol indicates important information that enables users to use the device more efficiently and cost-effectively.

### 1.4 Customer service

For technical advice, please contact our customer service department at:

Schaller Messtechnik GmbH  
Max-Schaller-Straße 99  
A - 8181 St.Ruprecht an der Raab

Telephone: +43 (0)3178 28899  
Fax: +43 (0)3178 28899 - 901

E-Mail: [info@humimeter.com](mailto:info@humimeter.com)  
Internet: [www.humimeter.com](http://www.humimeter.com)



© Schaller Messtechnik GmbH 2024

## 2. For your safety

The device complies with the following European directives:

- Restriction of Hazardous Substances in Electrical and Electronic Equipment (RoHS)
- Electromagnetic compatibility (EMC)

The device corresponds to state-of-the-art technology. However, it is still associated with a number of residual hazards.

These hazards can be avoided through strict observance of our safety information.

### 2.1 Proper use

- Easy to use device for quickly measuring the moisture content of wood chips
- Easy to use device for quickly measuring the moisture content of round and log wood
- The device must only be used for taking measurements on the products defined in the following sections of this manual (see "[6. Calibration curves](#)").

### 2.2 Improper use

- The device is not suitable for measuring frozen wood chips or wood chips with a temperature above +40 °C.
- The device is not suitable for measuring frozen wood or wood with a temperature above +50 °C.
- The device is not waterproof and must be protected from water and fine dust (IP40).

### 2.3 User qualifications

The device must only be operated by people who can be expected to reliably take the measurements. The device must not be operated by people whose reaction times may be slowed due to, e.g. the use of drugs, alcohol or medication.

All persons using this device must have read, understood and follow the instructions provided in the operating manual.

### 2.4 General safety information

The following safety information has to be observed at all times to avoid damage to objects and injury to people:

- 
- Remove the batteries if the device isn't used for a prolonged period of time (4 weeks).
  - Keep the insertion probe's measuring head away from your body throughout all activities.
  - Keep the ram electrode's measuring tips away from your body throughout all activities.
  - Keep the insertion probe's measuring head away from other people throughout all activities.
  - Keep the ram electrode's measuring tips away from other people throughout all activities.
  - In case of damages or loose parts on the device, remove the batteries and contact Schaller Messtechnik GmbH or your dealer.

All of the device's technical features have been inspected and tested before delivery. Every device has a serial number. Do not remove the tag with the serial number.

## 2.5 Warranty

The warranty does not apply to:

- Damage resulting from non-observance of the operating manual
- Damage resulting from third-party interventions
- Products that have been used improperly or modified without authorisation
- Products with missing or damaged warranty seals
- Damage resulting from force majeure, natural disasters, etc.
- Damage from improper cleaning
- Batteries older than six months
- Damage resulting from improper strain (pressure, bending) of the insertion probe or the measuring head
- Damage by dropping the measuring head

## 2.6 Packaging

- Do not discard the packaging!
- In case of returning the device for a warranty claim, the original packaging must be used.
  - » We refuse any liability for damages during transport using inadequate packaging.

## 3. On receipt of your device

### 3.1 Taking the device out of its packaging

- Take the device out of its packaging.
- Next, make sure that it is not damaged and that no parts are missing.

### 3.2 Making sure that all of the components have been included

Make sure that all of the components have been included by checking the package contents against the following list:

- humimeter BL2
- 4 pieces of AA Alkaline batteries
- Rubber protection cover
- Operating manual

Required accessories:

- External sensor (see "[Overview external sensors](#)" page 3)

Optional accessories for device:

- humimeter USB data interface module - USB flash drive with software and USB-cable or download using [humimeter.com/software](http://humimeter.com/software)
- Battery operated portable thermal printer (only possible together with humimeter USB data interface module) - Described in a separate operating manual
- Bluetooth module (only possible together with humimeter USB data interface module) - Described in a separate operating manual
- Wooden case
- Test block

Optional accessories for art. no. 12158 insertion probe for wood chips:

- Measuring head for humimeter BLL and BL2 (spare part)

Optional accessories for art. no. 12520 ram electrode:

- Set of 20 replacement tips for measuring electrodes, without insulation, 40 mm length
- Set of 20 replacement tips for measuring electrodes, without insulation, 60 mm length
- 2 replacement tips for measuring electrodes, insulated, 60 mm length
- Set of tips for measuring hay and straw bales, 255 mm length
- Plastic case (for device and ram electrode)

### 3.3 Inserting batteries

1. Remove the rubber protection cover. To do so, hold the rubber protection cover at the upper side and pull it over (figure 1 and 2). In case a sensor is connected, disconnect it before (see "4.4 Connecting the sensor to the device"). If your device is provided with an optional USB port, remove the protection cap of the USB socket before.
2. Take hold of the device with one hand, press your thumb onto the engraved area of the battery compartment (1) and drag downwards (2) (figure 3).
3. Insert the batteries with negative and positive terminals matching those indicated on the battery compartment. Press down the batteries so that they lay flat on the bottom of the housing (figure 4).
  - » As soon as all batteries have been inserted, the device switches on automatically.
4. Push the battery cover onto the housing until it clicks into place. Then mount the rubber protection cover onto the housing, beginning at the end where the battery compartment is situated (figure 5).

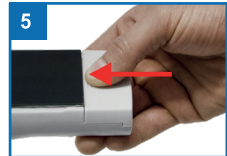
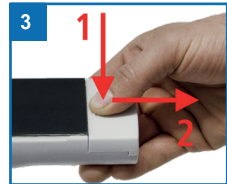

## 4. Using the device - Basics

### 4.1 Switching the device on



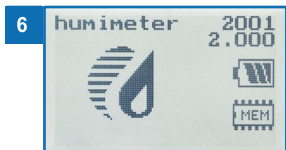

- Press the  button for 3 seconds.
- » The display will then show the status indicator (figure 6).
- » After inserting the batteries, the device switches on automatically.



## 4.2 Selecting the calibration curve

**To do so:** The device has to be in the product selection menu (figure 7).

For an overview of the different calibration curves and the criteria for selecting them, please refer to: "[6. Calibration curves](#)".

1. Press the  or  button to move from one product to the next Or
2. Press the  or  button for 3 seconds to open the calibration curve overview (figure 8).
3. Use the arrow keys to move from one calibration curve to the next
4. and keep any of them pressed to scroll through the types.
5. Confirm your selection by pressing 

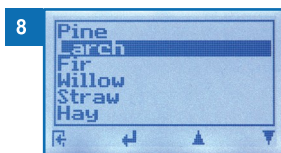
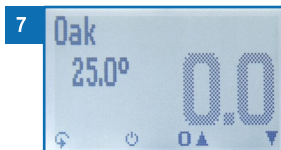

- » The calibration curve you selected will now be shown at the top of the display.

## 4.3 Connecting the cable to the sensor

- Insert the connector into the sensor until both threads are in place.
- » Pay attention to the increase in the connector and its correct positioning (figure 9).
- » The connector should fit without effort.
- Now tighten the thread by hand.



## 4.4 Connecting the sensor to the device

- If a sensor is already mounted, unscrew it counterclockwise.
- Plug the desired sensor into the device until both threads are in contact.
- » Pay attention to the elevation in the connector and its correct positioning (figure 11).
- » Do not use excessive force to plug in the sensor, which is very easy to operate.
- Now tighten the thread by hand.

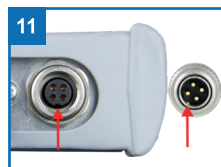

## 4.5 Inserting the measuring tips

- Unscrew the two nuts located on the head of the ram electrode counterclockwise (figure 12) .
  - » Loosen only the upper nuts. The nuts below must not be loosened!
- Insert one measuring tip per nut from behind through the nut (figure 13) .
  - » Measuring tips without insulation (article no. 12146 & 11775) always measure the wettest spot over the entire insertion depth.
  - » By using insulated measuring tips (article no. 11482) it is possible to determine the humidity at a defined measuring depth, as these only measure at the measuring tip.
  - » The tips for measuring hay and straw bales without insulation (article no. 12521) always measure the wettest spot over the entire insertion depth.
- Now screw the nuts with measuring tips to the threads located on the head of the ram electrode and tighten the nuts with the open-end wrench included in the scope of delivery (figure 14) .



### WARNING

#### Risk of injury

Risk of injury due to measuring tips

- ▶ Keep the measuring tips away from your body throughout all activities.
- ▶ Keep the measuring tips away from other people throughout all activities.

## 4.6 Taking a measurement

- For information on how to take a measurement, see section "[5. The measuring process](#)".

## 4.7 Switching the device off

**To do so:** The device has to be in the product selection or the Data Log menu. It is not possible to switch off the device when it is in the main menu.

- Press the  button for 3 seconds.

## 5. The measuring process

### 5.1 The measuring process with the insertion probe

#### 5.1.1 Preparing a measurement



**To do so:** The device has to have nearly the same temperature than the product being measured. It is recommended to let your humimeter device adjust to the surrounding temperature for at least 30 minutes before the measurement.

- Switch on the device (see "4.1 Switching the device on").



#### 5.1.2 Taking a measurement

**To do so:** The device has to have nearly the same temperature than the product being measured.

1. Insert the measuring head of the device straight into the wood chips (figure 17).
  - » Do not bend or drop the measuring head!
2. Connect the sensor plug to the device (see "4.4 Connecting the sensor to the device").
3. Select the desired calibration curve (see "6. Calibration curves"es") by pressing the  or  button (see "4.2 Selecting the calibration curve"rve") (figure 18).
4. The device will now instantly display the moisture content on the display (figure 19).
  - » The displayed value flashes when the moisture content exceeds the measuring range of the selected calibration curve (figure 20). A flashing value signals lowered accuracy of the measurement. The measuring range is dependent on the calibration curve (see "6. Calibration curves"es").
  - » Once the reading has been taken, it can be saved on the device (see "5.4 Saving individual readings" or "5.5 Saving several readings (a measurement

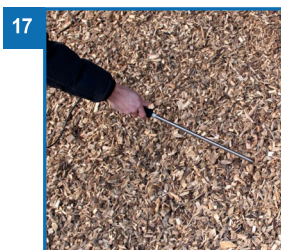

series) at the same time").



## CAUTION

### Risk of injury



Risk of injury due to the measuring head

- ▶ Keep the measuring head away from your body throughout all activities.
- ▶ Keep the measuring head away from other people throughout all activities.

## 5.2 The measuring process with the ram electrode

### 5.2.1 Preparing a measurement

**To do so:** The device has to have nearly the same temperature than the product being measured. It is recommended to let your humimeter device adjust to the surrounding temperature for at least 30 minutes before the measurement.

1. Insert the measuring tips (see "4.5 Inserting the measuring tips").
2. Select a suitable point for taking a measurement.
  - » Make sure that there are no knots, resin pockets or cracks in this area.
  - » Hint: Statistically, the spot that shows best the average moisture of the wood is at about 20% of the total wood length.
  - » Make sure that the measuring depth is between a quarter and a third of the diameter of the block or log. If necessary, cut away part of the diameter at the point to be measured.
3. If present, remove the bark at the point to be measured before starting the measurement (figure 21).
4. Switch on the device (see "4.1 Switching the device on").
5. Select the desired wood type (see "6.1 Calibration curves of the ram electrode"). To do so, press  or  (see "4.2 Selecting the calibration curve") (figure 23).

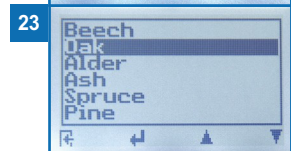

### 5.2.2 Taking a measurement

**To do so:** The device has nearly the same temperature than the product being measured. At the point to be measured the bark has been removed.

1. Put the ram electrode with measuring tips straight to the point to be measured (figure 24).

- » Make sure that the measuring tips are placed at right angles to the grain of the wood.
- » The ram electrode must not be dropped!

2. Hold the upper side of the ram electrode firmly, lift the metal handle and strike it downwards with force until the measuring tips penetrate the wood to the desired measuring depth (figure 25).

3. Connect the sensor plug to the device (see "4.4 Connecting the sensor to the device").

4. The device will now instantly display the moisture content on the display (figure 26).

- » The displayed value flashes when the moisture content exceeds the measuring range of the selected calibration curve (figure 27). A flashing value signals lowered accuracy of the measurement. The measuring range is dependent on the calibration curve (see "6. Calibration curves"es").

- » Once the reading has been taken, it can be saved on the device (see "5.4 Saving individual readings" or "5.5 Saving several readings (a measurement series) at the same time").



## WARNING

### Risk of injury

Risk of injury due to the measuring tips

- ▶ Keep the measuring tips away from your body throughout all activities.
- ▶ Keep the measuring tips away from other people throughout all activities.



## CAUTION

### Risk of injury

Crushing when striking the metal handle downwards.

- ▶ Hold the metal handle in the middle and pay attention to the position of your fingers.



## Information - Measuring accuracy

This rapid and non-destructive measuring procedure allows you to take moisture readings at a number of different points. When saving the individual readings, the device will automatically calculate the readings' average (see "5.5 Saving several readings (a measurement series) at the same time").



## Information - Incorrect readings











Always make sure to select the correct calibration curve for the material you are measuring. This prevents taking incorrect readings (see "11. Faults").

## 5.3 Hold function - Freezing the displayed value

The device can be configured in such a way that the information being shown on the display will freeze at the touch of a button until a new button is pressed. This function can be very useful when e.g. taking readings in spaces where it is not possible to see the display.

### 5.3.1 Activating the Hold function in the Options menu

**To do so:** The device has to be switched on and be in the product selection menu.

1. Press  twice or hold for 2 seconds.
2. Select **Options**. To do so, press  or  and confirm by pressing .
3. Select **Log Time** (figure 28). To do so, press  or  and confirm by pressing .
4. Select **Hold** (figure 29). To do so, press  or  and confirm by pressing .

28

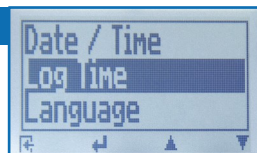

29

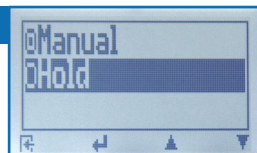



» The setting has been saved.

5. Press  to leave the **Options** menu.

6. Press  to leave the main menu.

### 5.3.2 Using the Hold function

**To do so:** The device has to be switched on and be in the Data Log menu (see "Data Log menu" page 6).

- Press .
- » The current reading will be frozen. All of the four symbols will now be displayed as  (figure 30).
- To reactivate the frozen display, simply press any button.

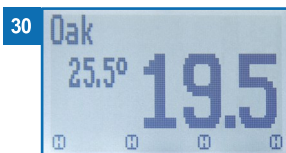













## 5.4 Saving individual readings

The device can be configured in such a way that the device will save a reading every time a button is pressed. This option (manual save function) is the device's default setting.

### 5.4.1 Activating the manual save function in the options menu





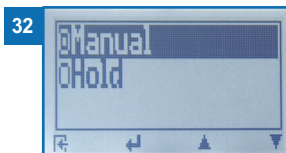
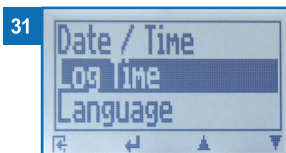





**To do so:** The device has to be switched on and be in the product selection menu.

1. Press  twice or hold for 2 seconds.
2. Select **Options**. To do so, press  or  and confirm by pressing .
3. Select **Log Time** (figure 31). To do so, press  or  and confirm by pressing .
4. Select **Manual** (figure 32). To do so, press  or  and confirm by pressing 
  - » The setting has been saved.
5. Press  to leave the **Options** menu.
6. Press  to leave the main menu.



## 5.4.2 Using the manual save option

**To do so:** The device has to be in the Data Log menu (see "Data Log menu" page 6). The manual save option is set on the device.

1. Press .
  - » The display will now appear as shown in figure 34 and the disc symbol will be preceded by the digit one.
2. Press  to enter a name for the saved reading and to finish the measuring process.
  - » The display will now appear as shown in figure 35.
3. The data you have inputted can be overwritten at any time.
4. **Inputting letters:**  
Press and hold  to quickly scroll to the required letter and either press it for 3 seconds or press  to confirm the selected letter (figure 36).
5. **Inputting numbers:**  
Press and hold  to quickly scroll to the required number and either press it for 3 seconds or press  to confirm the selected number.
6. **Moving forward/back:**  
Press  to switch to another input level. Press  or  to move forward or back.
7. Confirm your entry by pressing .
  - » The data you entered has been saved.

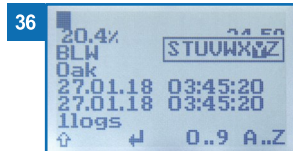
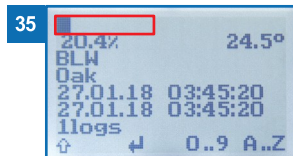
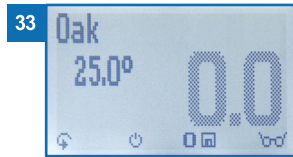



## 5.5 Saving several readings (a measurement series) at the same time

**To do so:** The device has to be in the Data Log menu.

1. Take several readings (see "5. The measuring process").
2. After each measurement, press  to save the reading.

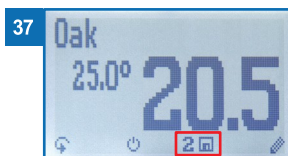
» The display will appear as shown in figure 37. The marked number shows the number of readings that have already been saved.



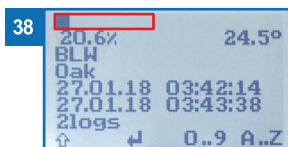

3. Press  to enter a name for the saved measurement series and to finish the measuring process.
- » The display will now appear as shown in figure 38.





4. The data you have inputted can be overwritten at any time.

### 5. Inputting letters:

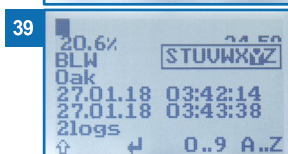
Press and hold  to quickly scroll to the required letter and either press it for 3 seconds or press  to confirm the selected letter (figure 39).



### 6. Inputting numbers:

Press and hold  to quickly scroll to the required number and either press it for 3 seconds or press  to confirm the selected number.

### 7. Moving forward/back:

Press  to switch to another input level. Press  or  to move forward or back.

8. Confirm your entry by pressing .

» The data you entered has been saved.

» The device automatically determines the average moisture content of the saved measuring values.



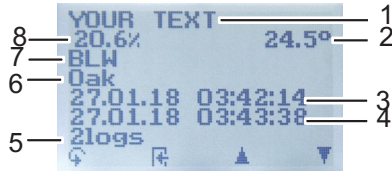

» The display will show the following information:



No.	Name
1	Name of the measurement series (editable)
2	Temperature (average)
3	Date & start time of the measurement series
4	Date & end time of the measurement series
5	Number of saved readings
6	Calibration curve
7	Device name
8	Moisture content (average)

## 5.6 Viewing individual readings





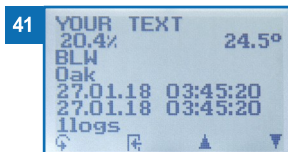



**To do so:** You must have saved a reading (e.g. **1 Log**). The display will now appear as shown in figure 40.

1. Press .
2. Select the required reading. To do so, press  or .
  - » The display will now appear as shown in figure 41.
  - » Press  to leave this screen.



## 5.7 Viewing individual readings from a series of measurements





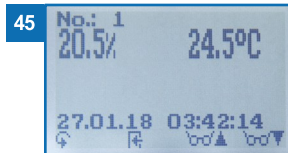
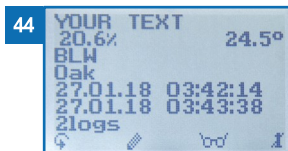
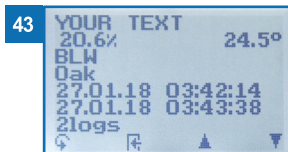





**To do so:** You must have saved a series of measurements (e.g. **2 logs**). The display will now appear as shown in figure 42.

1. Press .
2. Select the required reading. To do so, press  or .
  - » The display will now appear as shown in figure 43.
3. Press  to switch to another input level.
  - » The display will now appear as shown in figure 44.
4. Press  again.
  - » The display will now appear as shown in figure 45.
5. Navigate to the required reading (**No.: 1, No.: 2, No.: 3**). To do so, press  or .
6. Press  to leave this screen.



## 5.8 Deleting all measured values (data log)



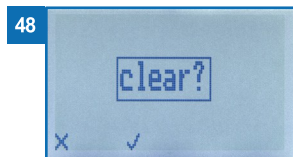
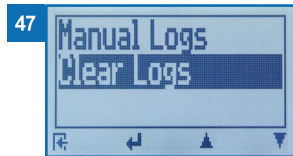

**To do so:** You must have taken and saved one or several readings.

1. Press  twice or hold for 2 seconds.
2. Select **Edit Logs** (figure 46). To do so, press  or  and confirm by pressing .
3. Select **Clear logs** (figure 47). To do so, press  or  and confirm by pressing 
  - » The display will show the message **clear?** (figure 48).
4. Confirm by pressing 
  - » The data log has been deleted.
5. Press  to leave the **Edit Logs** menu.
6. Press  to leave the main menu.



## 5.9 Deleting individual measurement series

**To do so:** You must have saved a measured value (e.g. **1 log**) or a series of measurements (e.g. **3 logs**). The display will now appear as shown in figure 49.

1. Press 
  - » The display will now appear as shown in figure 50.
2. Select the required reading. To do so, press  or .
3. Press  to switch to another input level.
  - » The display will now appear as shown in figure 51.
4. Press .

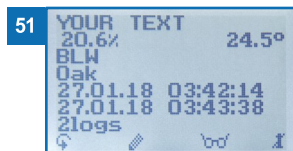
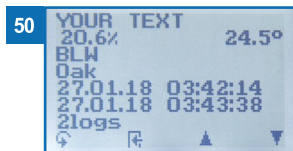

- » The display will then show the message **clear?** (figure 52).

5. Confirm by pressing .

- » The value has been deleted.

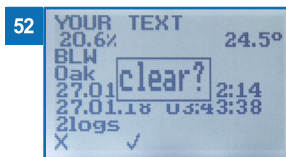



## 5.10 Deleting single values from a series of measurements

**To do so:** You must have saved a series of measurements comprising of at least 2 logs. The display will now appear as shown in figure 53.

1. Press .

- » The display will now appear as shown in figure 54.



2. Select the required reading. To do so, press  or .

3. Press  to switch to another input level.

- » The display will now appear as shown in figure 55.

4. Press .

- » The display will now appear as shown in figure 56.

5. Select the required measured value. To do so, press  or .

6. Press  to switch to another input level.

- » The display will now appear as shown in figure 57.

7. Press  to delete the value shown.

- » The display will then show the message **clear?** (figure 58).

8. Confirm by pressing .

- » The value has been deleted.

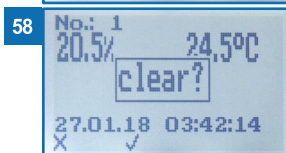
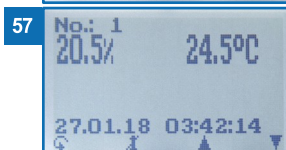
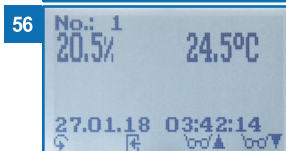
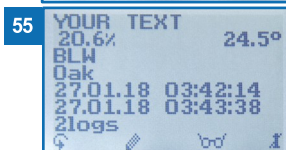
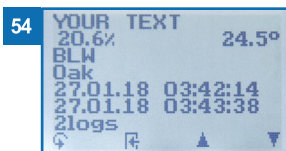

---

## 6. Calibration curves

The device automatically recognises the connected sensor and provides the corresponding calibration curves.

With no sensor attached to the device, the calibration curves for the ram electrode will be provided (see "[Overview external sensors](#)" page 3).

### 6.1 Calibration curves of the ram electrode

Wood type	Sub categories	Measuring range limit
Beech	Rubber, Eucalyptus	32 %
Oak	Mahogany, Wenge	32 %
Alder	Acacia, Alstonia, Birch, European chestnut, Horse chestnut, Cherry Tree, Walnut, Okan	40 %
Ash	Keruing	35 %
Spruce		40 %
Pine	Balsa, Yew Tree, Stone Pine	35 %
Larch	Maple, Douglas Fir, Hemlock, Poplar, Elm	32 %
Fir	Ceiba, Lime	37 %
Willow	Pear, Hickory, Olive wood, Ramin, Teak	40 %
Straw	Straw bales (art. no. 12521 required) Compressed density from 100 kg/m <sup>3</sup> to 130 kg/m <sup>3</sup>	30 %
Hay	Hay bales (art. no. 12521 required) Compressed density from 100 kg/m <sup>3</sup> to 130 kg/m <sup>3</sup>	25 %
Cellulose	Cellulose insulation material (art. no. 12521 required) Density from 38 to 65 kg/m <sup>3</sup>	35 %
Digit 1	Special products	0 - 100
Empty 1	Free curve for special products	
Test block	! Only for testing the moisture meter !	

**Explanations to wood types and sub categories:**

The wood types listed in the "Wood type" column are displayed in the measurement window of the humimeter BL2. If you want to measure a type of wood that is not displayed on the device, search for it in the subgroups and set the corresponding wood type on the device, e.g. if you measure poplar, set the wood type larch on the device.

**6.2 Calibration curves of the insertion probe**

Calibration curve	Product type	Measuring range
Wood chips	See "6.3.1 Wood chips"	10 % - 50 %
Coarse wood chips	See "6.3.2 Coarse wood chips"	10 % - 50 %
Industrial wood chips	See "6.3.3 Industrial wood chips"	10 % - 50 %
Pellets	Wooden pellets	11 % - 20 %
Sawdust	Sawdust	14 % - 50 %
Olive stones	Shredded olive stones	10 % - 21 %
Digit 2	Special products	0 - 100
Empty 2	Free curve for special products	
Test block	! Only for testing the moisture meter !	

**6.2.1 Definition wood chip types (in accordance with EN ISO 17225-1)**

The given numbers refer to the particle sizes that fit through the round screen openings.

- P16            at least 75 % of the mass between 3.15 and 16 mm
- P31            at least 75 % of the mass between 8 and 31.5 mm
- P45            at least 75 % of the mass between 8 and 45 mm
- P63            at least 75 % of the mass between 8 and 63 mm

---

## 6.3 Selection of calibration curve for wood chips

The calibration curves for wood chips depends on the wood type (hardwood, softwood), the size of the chips (size classes according to norm EN ISO 17225-1) as well as on the content of fine fraction.

If you are not sure which calibration curve is the best suited for your material, it is recommended to carry out a reference measurement by kiln-drying (according to EN ISO 18134-2).

Schaller Messtechnik GmbH will be happy to advise you on the selection of the right calibration curve. Please send a picture of your wood chips, placing a measuring tape to the material, to [support@schaller-gmbh.at](mailto:support@schaller-gmbh.at). You will receive a recommendation from us immediately.

### 6.3.1 Wood chips

For wood chips with fine fraction, mainly consisting of hardwood (maximum proportion of softwood of 30 %). For wood chips sizes from P31 to P45. The fine fraction mainly derives from barks, small branches and bushes. See example pictures [59](#) and [60](#).

If your wood chips don't contain small parts (few fine fraction or no fine fraction) or if the wood chips contain a higher proportion of softwood, use one of the following calibration curves.

### 6.3.2 Coarse wood chips

For coarse wood chips without fine fraction, mainly consisting of hardwood (maximum proportion of softwood of 30 %). This curve also has to be used for wood chips with fine fraction, mainly consisting of softwood, with a proportion of softwood (spruce, fir, pine, larch) of 70 % and more. For wood chips sizes from P31 to P63. See example pictures [61](#) and [62](#).

If your wood chips mainly consist of softwood and don't contain small parts (few fine fraction or no fine fraction), use the following calibration curve.

### 6.3.3 Industrial wood chips

For coarse wood chips without fine fraction, mainly consisting of softwood, with a proportion of softwood (spruce, fir, pine, larch) of 70 % and more. For wood chips sizes from P45 to P63. This curve is predominantly suited for measuring wood chips deriving from logs and full trees as well as sawmill residues without fine fraction. See example pictures [63](#) and [64](#).

Example pictures wood chips



Example pictures coarse wood chips



Example pictures industrial wood chips



---

### 6.3.4 Compression of wood chips

The humimeter BL2 is calibrated for normally compressed wood chips. If the wood chips being measured are much less or much more compressed, the accuracy of the measurement will decrease. Normally compressed wood chips are defined in norm EN 15103 (determination of the bulk density).

## 6.4 How moisture is defined

In the standard delivery state, the device measures and shows the material moisture content. The moisture content readings are calculated in relation to the material's overall mass:

$$\%WG = \frac{M_n - M_t}{M_n} \times 100$$

$M_n$ : Mass of the sample with average moisture content

$M_t$ : Mass of the sample with zero moisture content

%WG: Moisture content (in accordance with EN ISO 18134-2)

Example: 1 kg wood with 40 % moisture content

The total weight of 1 kg (corresponding to 100%) consists of 0.6 kg (60 %) wood and 0.4 kg (40 %) water.

## 6.5 Definition of wood moisture

The wood moisture defines the amount of water contained in the material in relation to the material's dry weight.

Example: 0.6 kg wood with 0.4 kg water

The dry weight of 0.6 kg corresponds to 100 %. In relation to the dry weight, the 0.4 kg water result in a wood moisture of 66.7 %.

It is possible to set the device to the calculation of wood moisture at the factory. For that please contact [support@schaller-gmbh.at](mailto:support@schaller-gmbh.at).

## 6.6 Notes for comparative measurement with oven-drying method

The device uses a much higher sample quantity than the drying oven (12-fold to 20-fold quantity of kiln-drying method). Furthermore, to determine a more accurate average moisture value in case of inhomogeneous material, there can be effected several measurements within a short time.

Considering a sampling error due to the considerably smaller sample quantity as well as the content of volatile matters (resin etc.) that are not water, the kiln-drying method will practically reach an accuracy of approx.  $\pm 3\%$ . Therefore, if the measuring values of these two very different methods of determining the water content are compared, differences of  $\pm 3\%$  can be considered to be normal.

In the standard EN ISO 18134-2 is declared that the drying oven method provides no absolute values, but only comparable values.

---

## 7. Using the LogMemorizer program

**To do so:** The device is provided with USB interface, and the USB stick with LogMemorizer software and USB cable are available. Otherwise, you can also install the software at [humimeter.com/software](http://humimeter.com/software) or by scanning the QR code.



### 7.1 Installing/opening the program

1. Insert the USB stick with the LogMemorizer program into the USB port on your computer or
  - » download the LogMemorizer software at [humimeter.com/software](http://humimeter.com/software) or use the QR code.
2. Open the **setup** application.
3. Follow the installation instructions.
4. Open LogMemorizer.
  - » The screen will now display the LogMemorizer's interface (figure 65).

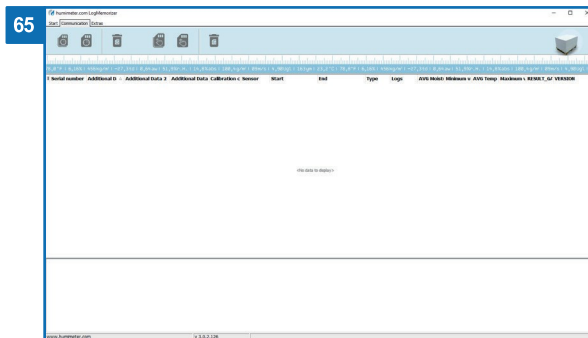

- » Before using LogMemorizer, please refer to the the separate LogMemorizer operating manual for the correct configuration of the USB COM Port.

For more information on LogMemorizer, please refer to the separate LogMemorizer operating manual supplied with the device.







## 7.2 Exporting measured values to a computer

**To do so:** The LogMemorizer program is installed. You must have taken and saved one or several moisture readings.

**Options:** You can export moisture readings from the humimeter BL2 or initiate the export at your computer.

### Exporting moisture readings from the humimeter BL2

Connect the humimeter BL2 to your computer using the supplied USB cable:

1. Insert the USB Mini B connector into the humimeter BL2 (figure 66).
2. Insert the USB connector into the computer.
3. Open LogMemorizer on your computer.
4. Switch on the humimeter BL2.
5. Press  twice or hold for 2 seconds.
6. Select **Send Logs** (figure 67). To do so, press  or  and confirm by pressing .
7. Select **Manual Logs** (figure 68). To do so, press  or  and confirm by pressing .
8. The display will then show the message **Send** (figure 69).
  - » All measuring values saved on the humimeter BL2 will now be sent to your computer.

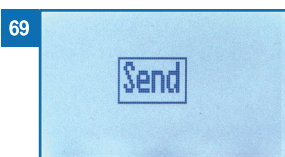
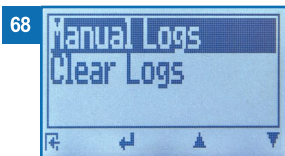
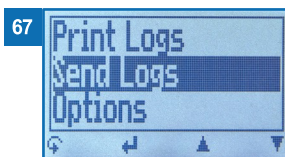

### Initiating the data export at your computer

Connect the humimeter BL2 to your computer using the supplied USB cable:

1. Insert the USB Mini B connector into the humimeter BL2 (figure 70).
2. Insert the USB connector into the computer.
3. Open LogMemorizer on your computer.



4. Switch on the humimeter BL2.
5. Open the **Communication** tab in LogMemorizer (figure 71).

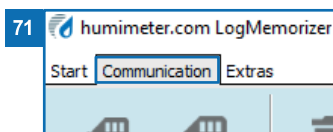



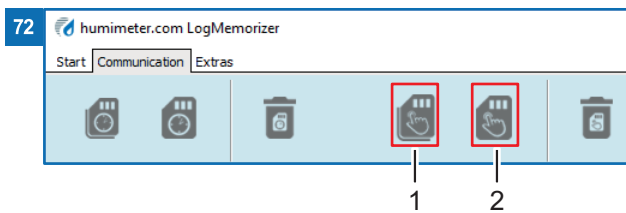

6. Select and click on one of the two buttons shown in figure 72.
  - » **Import all manual logs** (for importing all manually saved readings) or
7. **Import most recent manual log** (for importing the most recent manually saved logs).



No.	Name
1	Import all manual logs
2	Import most recent manual log



- » The measuring values saved on the humimeter BL2 will now be sent to your computer.

## 8. Checking on the device's status

1. Press  twice or hold for 2 seconds.
2. Select **Status**. To do so, press  or  and confirm by pressing .
  - » The display will then show the status indicator **humimeter**.
  - » The display will show the following information:



No.	Name
1	Serial number
2	Software version
3	Battery status
4	Memory status

3. Confirm by pressing .
4. Press  to leave the main menu.















---

## 9. Configuring the device

### 9.1 Turning on Bluetooth







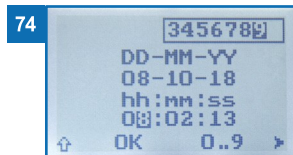
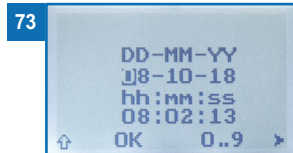





The information on Bluetooth is provided in a separate operating manual.

### 9.2 Adjusting the date/time

1. Press  twice or hold for 2 seconds.
2. Select **Options**. To do so, press  or  and confirm by pressing .
3. Select **Date/Time**. To do so, press  or  and confirm by pressing .
  - » The display will now appear as shown in figure 73.
  - » The format for the date is **DD-MM-YY** (Day-Month-Year).
  - » The format for the time is **hh:mm:ss** (Hour:Minutes:Seconds).
4. **Inputting numbers:**  
Press and hold  to quickly scroll to the required number and either press it for 3 seconds or press  to confirm the selected number (figure 74).
5. **Moving forward:**  
To move forward between **DD-MM-YY** and **hh:mm:ss**, press .
6. **Moving back:**  
Press  to switch to another input level. To move backward between **DD-MM-YY** and **hh:mm:ss**, press .
7. Confirm the date/time by pressing **OK**.
  - » The settings have been saved.
8. Press  to leave the **Options** menu.
9. Press  to leave the main menu.















### 9.3 Selecting a language

1. Press  twice or hold for 2 seconds.
2. Select **Options**. To do so, press  or  and confirm by pressing .
3. Select **Language**. To do so, press  or  and confirm by pressing .
4. Navigate to the required language. To do so, press  or  and confirm by pressing .
- » The settings have been saved.
5. Press  to leave the **Options** menu.
6. Press  to leave the main menu.



### 9.4 Activating options

**To do so:** Some of the options must be deactivated.

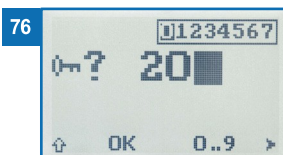
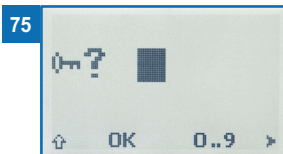
1. Press  twice or hold for 2 seconds.
2. Select **Options**. To do so, press  or  and confirm by pressing .
3. Select **Unlock**. To do so, press  or  and confirm by pressing .
- » The display will now appear as shown in figure 75.
- » On delivery, the four-digit password is the device's serial number.
4. **Inputting numbers:**  
Press and hold  to quickly scroll to the required number and either press it for 3 seconds or press  to confirm the selected number (figure 76).
5. **Moving back:**  
Press  to switch to another input level.  
To move back, press .
6. Confirm the four-digit password by pressing .
- » The settings have been saved.



- 
- » The **°C/°F**, **BL On Time**, **Auto Off Time**, **Materialcalibration**, **Password**, **Reset** options are now activated.













7. Press  to leave the **Options** menu.
8. Press  to leave the main menu.

## 9.5 Deactivating options

Once the device has been switched restarted, the **°C/°F**, **BL On Time**, **Auto Off Time**, **Materialcalibration**, **Password**, **Reset** options will be deactivated again.

## 9.6 Selecting °C/°F

**To do so:** All of the options must be activated (see "9.4 Activating options").





1. Press  twice or hold for 2 seconds.
2. Select **Options**. To do so, press  or  and confirm by pressing .
3. Select **°C/°F**. To do so, press  or  and confirm by pressing .
4. Navigate to the required temperature scale, i.e. Celsius (**°C**) or Fahrenheit (**°F**). To do so, press  or  and confirm by pressing .
- » The settings have been saved.
5. Press  to leave the **Options** menu.
6. Press  to leave the main menu.

## 9.7 Reducing the device's power consumption

### 9.7.1 Configuring the display illumination time













**To do so:** All of the options must be activated (see "9.4 Activating options").

1. Press  twice or hold for 2 seconds.
2. Select **Options**. To do so, press  or  and confirm by pressing .
3. Select **BL On Time**. To do so, press  or  and confirm by pressing .

4. Select the required display illumination period (30 seconds, 2 minutes, 5 minutes, 10 minutes). To do so, press  or  and confirm by pressing .
- » The settings have been saved.
5. Press  to leave the **Options** menu.
6. Press  to leave the main menu.

### 9.7.2 Configuring automatic switch-off

**To do so:** All of the options must be activated (see "9.4 Activating options").

1. Press  twice or hold for 2 seconds.
2. Select **Options**. To do so, press  or  and confirm by pressing .
3. Select **Auto Off Time**. To do so, press  or  and confirm by pressing .
4. Select the period of time you want the device to stay switched on (3 minutes, 5 minutes, 10 minutes). To do so, press  or  and confirm by pressing .
- » The settings have been saved.
5. Press  to leave the **Options** menu.
6. Press  to leave the main menu.









---

## 9.8 Configuring the material calibration function

The type calibration function is described in a separate operating manual.

## 9.9 Changing the password



**To do so:** All of the options must be activated (see "9.4 Activating options").

1. Press  twice or hold for 2 seconds.
2. Select **Options**. To do so, press  or  and confirm by pressing .
3. Select **Password**. To do so, press  or  and confirm by pressing 
  - » The display will show the current password.
4. Overwrite the current password. To do so, press and hold **0..9** to quickly scroll to the required number and either press it for 3 seconds or press  to confirm the selected number.

### Moving back:









Press  to switch to another input level.

To move back, press .

5. Confirm the new four-digit password by pressing **OK**.
  - » The settings have been saved.
6. Press  to leave the **Options** menu.
7. Press  to leave the main menu.

## 9.10 Resetting the device to its factory settings

**To do so:** All of the options must be activated (see "9.4 Activating options").

1. Press  twice or hold for 2 seconds.
2. Select **Options**. To do so, press  or  and confirm by pressing .
3. Select **Reset**. To do so, press  or  and confirm by pressing 
  - » The display will then show the message **Reset?** (figure 77).
4. Confirm by pressing 
  - » The device will now be reset to its factory settings. All of your personal settings will be lost.
  - » The display will show the status indicator **humimeter** (figure 78).
  - » Resetting the device will not affect the saved measuring values.

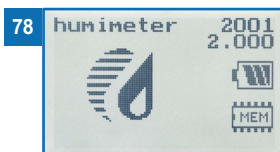
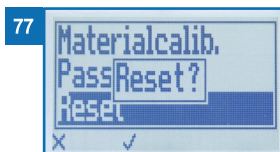

## 10. Cleaning and maintenance

Regularly cleaning and maintaining the device will ensure that it will have a long service life and stay in good condition.

### 10.1 Changing the batteries

The device constantly monitors the charge level of the batteries. The current battery status is shown on the status screen.

If the battery's charge is very low, the battery symbol will be shown with an exclamation mark. In that case, the batteries must be changed immediately (figure 80).

For changing the batteries, see section "3.3 Inserting batteries".

As the device's user, you are responsible by law for properly disposing of all used batteries, which must not be disposed of as domestic waste (Battery Directive).

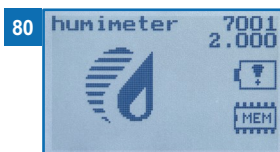
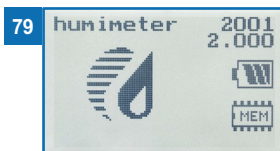

---

## 10.2 Checking the calibration

**To do so:** Test block art. no. 12308 required. The device and the test block must have a temperature between 20.0 °C and 26.0 °C.

Via the test block art. no. 12308, the calibration of both the insertion probe and the ram electrode can be checked.

1. Switch on the device and select the calibration curve "test block" using the arrow keys (see "4.2 Selecting the calibration curve" rve").
2. Hold side 1 of the test block to the measuring head of the insertion probe (figure 81) or to the measuring tips of the ram electrode (figure 82).
  - » The displayed measuring value has to be 22.0 % (+/- 1.0 %) (the moisture reading will be displayed in black) (figure 83).
  - » If the moisture value is outside this range, in which case it will be displayed in grey (figure 84), please contact your dealer or Schaller Messtechnik GmbH.
3. Hold side 2 of the test block to the measuring head of the insertion probe (figure 85) or to the measuring tips of the ram electrode (figure 82).
  - » The displayed measuring value has to be 41.0 % (+/- 1.0 %) (the moisture reading will be displayed in black) (figure 86).
  - » If the moisture value is outside this range, in which case it will be displayed in grey, please contact your dealer or Schaller Messtechnik GmbH.

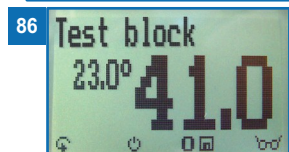
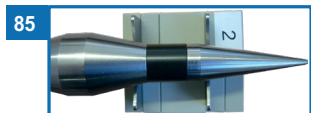
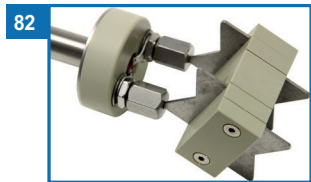
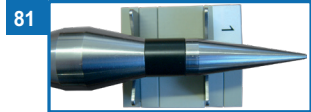

### 10.3 Care instructions

- Do not leave the device out in the rain. The device is not waterproof.
- Do not expose the device to extreme temperatures.
- Protect the device from strong mechanical shocks and loads.

### 10.4 Cleaning the device

#### Plastic housing

- Clean the plastic housing with a dry cloth.

#### Measuring head of insertion probe

- The measuring head can be cleaned with a cloth and cleaning alcohol.

#### Measuring tips of ram electrode

- The measuring tips can be cleaned with a cloth and cleaning alcohol.

#### Test block

- The test block can be cleaned with a moistened lint-free cloth.



## ATTENTION

### **Do not clean with fluids**

Water or cleaning fluid getting inside the device can destroy the device.

- ▶ Only clean the plastic housing with dry materials.

---

## 11. Faults

If the measures listed below fail to remedy any faults or if the device has faults not listed here, please contact Schaller Messtechnik GmbH.

Fault	Cause	Remedy
General measuring errors	Temperature discrepancy between device and material being measured	Let the temperature adjust to the material being measured (permitted difference of max. 3 °C).
	Wrong calibration curve	Check whether you have selected the right calibration curve (product) before taking a reading (see "6. Calibration curves"es").
	Moldy or rain wet material	The accuracy of the measurement decreases significantly.
Measuring errors insertion probe	Frozen material	The accuracy of the measurement decreases significantly.
	The temperature of the material being measured is too low or high. I.e. the material's temperature is lower than 0 °C or higher than +40 °C.	The temperature of the material being measured has to be between 0 °C and +40 °C.
	Wood chips mixed with snow	The accuracy of the measurement decreases significantly.
	Movement of the measuring tip after inserting	Do not move the measuring tip after inserting.
	Water film on the measuring head	After measuring wet wood chips, on the measuring head may arise a water film. Clean the measuring head (see "10.4 Cleaning the device").
Measuring errors ram electrode	The temperature of the material being measured is too low or high	The temperature of the material being measured has to be between 0 °C and +50 °C.
	Bark beetle infested wood	The accuracy of the measurement decreases significantly.

Fault	Cause	Remedy
	Measurement through the bark	The accuracy of the measurement decreases significantly, even if using insulated measuring tips.
<a href="#">Sources of error when checking the calibration</a>	Contact pressure	Make sure the test block is in good contact with both metal contacts.
	Position	The device will display the value 0.0 % if the test block isn't positioned correctly.
	Polluted test block	Make sure that the test block is free from dust, dirt, oil and dampness. Clean it if necessary (see " <a href="#">10.4 Cleaning the device</a> ").
	Wrong calibration curve	Check whether you have selected the calibration curve "Test block" before starting the test.
<a href="#">Data transfer to Log Memorizer failed</a>	Interface has not been configured	The interface only has to be configured once. To do so, press the F1 key on your computer and read the Help file of the LogMemorizer program.

---

## 12. Accessories

### 12.1 BL2 tube extension

Optional accessory for extending the measuring tube one meter. Art.No. 12467

#### 12.1.1 Overview tube extension and humimeterBL2

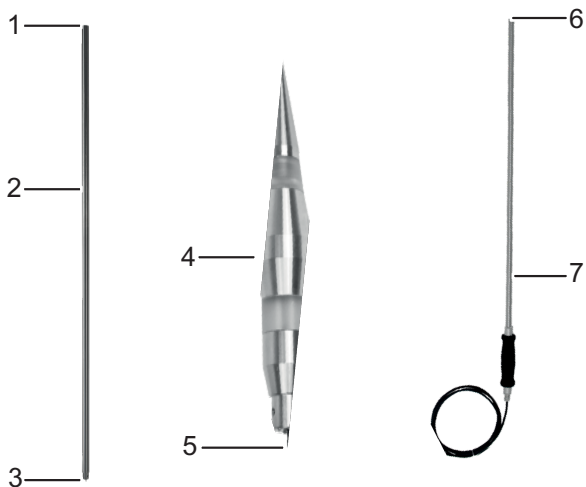

No	Name
1	Socket extension
2	Extension (tube)
3	Connenction extension
4	Measuring tip
5	Connection tip
6	Socket basic unit BLL
7	Basic unit BLL

### 12.1.2 Demounting of the measuring tip



#### CAUTION

##### Risk injury

Risk of injury through the measuring tip.

- ▶ Keep the measuring tip away from your body during all activities.
- ▶ Keep measuring tip away from other peoples' bodies during all activities.

Remove the batteries from the humimeter BLL.

Loosen the two screws which fix the measuring tip in the tube with a PH1 cross-head screwdriver.

Now carefully pull the tip out of the tube and release the connector between the tip



and the tube.

### 12.1.4 Installation of the extension

Place the tube on the basic humimeter BLL unit together with the extension tube on a table.

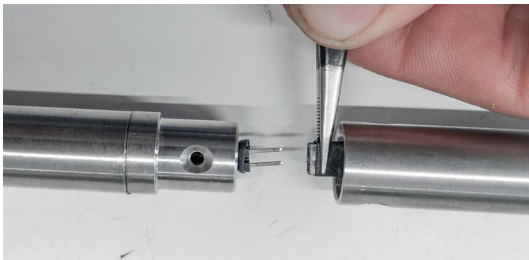

Now insert the connector of the extension into the socket of the basic unit. (The socket can be held with tweezers, for example.) Make sure that the connector is pushed all

---

the way into the socket.

Now carefully insert the extension tube into its basic unit tube.

Align the tube by twisting it, so the holes match up in order to apply the screws.

Now tighten the two M3x5 countersunk screws again.

### 12.1.5 Tip assembly

Carefully insert the plug of the measuring tip into the socket of the tube. (The socket can be held in place with tweezers, for example).



Now carefully insert the measuring tip into the tube. Now align the measuring tip by twisting it so that the holes match in order to attach the screws.

Now tighten the two M3x5 countersunk screws again.

### 12.1.6 Function test

Reconnect the tube with the humimeter BL2 basic unit and turn it on.

Hold the measuring tip in the air: The measuring device must display a moisture value of 0.0.

Now grab the measuring tip with your hand: The measuring instrument must display a moisture value between 5 % and 50 %.

## 12.2 Changing the measuring head (tip)

If the measuring head is defective (e.g. the tip is broken), you can exchange it. For this purpose, the item: "Measuring head humimeter BLL (spare part)" Art.No. 12472 is required.

Please perform the steps described in item "[12.1.2 Demounting of the measuring tip](#)" [page 54](#) and "[12.1.5 Tip assembly](#)" [page 55](#) . Then perform a functional test. See "[12.1.6 Function test](#)" [page 55](#)

## 13. Storage and disposal

### 13.1 Storing the device

The device must be stored as follows:

- Do not store outdoors.
- Store in a dry and dust-free place.
- Protect the device from sunlight.
- Avoid mechanical shocks/loads.
- Remove the batteries if the device isn't used for a period of 4 weeks or longer.
- Storage temperature: -20 °C to +60 °C

### 13.2 Disposing of the device



Devices marked with this symbol are subject to Directive 2012/19/ EU of the European Parliament and of the Council of 4 July 2012 on waste electrical and electronic equipment (WEEE).

If the device is being operated outside the European Union, the national regulations on the disposal of such devices that apply in the country of use must be observed.



Electronic devices must not be disposed of as domestic waste.

The device must be disposed of appropriately using appropriate collection systems.

---

## 14. Device information

### 14.1 EC declaration of conformity

# CE KONFORMITÄTSERKLÄRUNG DECLARATION OF CONFORMITY

---

Name/ Adresse des Herstellers: **Schaller Messtechnik GmbH**

*Name/ address of manufacturer:* **Max-Schaller-Straße 99  
A – 8181 St. Ruprecht**

Produktbezeichnung: **humimeter**

*Product designation:*

Typenbezeichnung: **BL2 ; BLL ; BLH ; BLW ; FL1 ; FL2 ; FLH ; FLM ; FLS ; RM1;  
SLW ; WLW**

*Type designation:*

Produktbeschreibung: **Messgerät zur Bestimmung des Wassergehalts in  
Biomasse und diversen Schüttgütern**

*Product description* **Measuring device for determining the water content in bio-  
mass and various bulk materials**

Das bezeichnete Produkt erfüllt die Bestimmungen der Richtlinien:

*The designated product is in conformity with the European directives:*

**EMV - Richtlinie 2014/30/EC**

**EMC Directive 2014/30/EU**

**RoHS - Richtlinie 2011/65/EG**

**RoHS-Directive 2011/65/EU**

Die Übereinstimmung des bezeichneten Produktes mit den Bestimmungen der Richtlinien wird durch die vollständige Einhaltung folgender Normen nachgewiesen:

*Full compliance with the standards listed below proves the conformity of the designated product with the provisions of the above-mentioned EC Directives:*

**EN 61326-1:2013**

Elektrische Mess-, Steuer-, Regel- und Laborgeräte - EMV-Anforderungen  
*Electrical equipment for measurement, control, and laboratory use – EMC requirements*

**EN IEC 63000:2019-05**  
*ersetzt / replaced*  
**EN 50581:2012**

Technische Dokumentation zur Beurteilung von Elektro- und Elektronikgeräten hinsichtlich der Beschränkung gefährlicher Stoffe.  
*Technical documentation for the assessment of electrical and electronic products with respect to the restriction of hazardous substances.*

Für das angeführte Produkt ist eine vollständige Dokumentation mit Betriebsanleitung in Originalfassung vorhanden.

*For the mentioned product a complete documentation with manual of instruction in original version is available.*

Bei Änderungen, die nicht vom Hersteller spezifiziert sind, verliert diese Konformitätserklärung die Gültigkeit.

*In case of any changes not agreed upon with the manufacturer, this declaration of conformity loses its validity.*

St. Ruprecht a.d. Raab, 31.07.2022

 **Schaller**  
Messtechnik / humimeter.com  
Schaller Messtechnik GmbH  
1120 - Schaller - 53470 - 99  
AT - 819 - St. Ruprecht a.d. Raab  
www.humimeter.com | info@humimeter.at  
.....  
Bernhard Maunz  
Rechtsverbindliche Unterschrift des Ausstellers  
Legal binding signature of the issuer



## DECLARATION OF CONFORMITY

---

Name/ address of manufacturer: **Schaller Messtechnik GmbH**  
**Max-Schaller-Straße 99**  
**A – 8181 St. Ruprecht**

Product designation: **humimeter**

Type designation: **BL2 ; BLL ; BLH ; BLW ; FL1 ; FL2 ; FLH ; FLM ; FLS ; RM1 ;  
SLW ; WLW**

Product description: **Measuring device for determining the water content in bio  
mass and various bulk materials**

The designated product is in conformity with the following directives:

- **Electromagnetic Compatibility Regulations 2016 Great Britain**
- **RoHS-Directive 2011/65/EU Directive on the restriction of the use of certain hazardous substances in electrical and electronic equipment**

Full compliance with the standards listed below proves the conformity of the designated product with the provisions of the above-mentioned Directives:

<b>EN 61326–1:2013</b>	Electrical equipment for measurement, control, and laboratory use – EMC requirements
<b>EN IEC 63000:2019-05</b> replaced <b>EN 50581:2012</b>	Technical documentation for the assessment of electrical and electronic products with respect to the restriction of hazardous substances.

For the mentioned product, a complete documentation with manual of instruction in original version is available.

In case of any changes not agreed upon with the manufacturer, this declaration of conformity loses its validity.

St. Ruprecht a.d. Raab, 31.07.2022



**Schaller**  
Messtechnik / humimeter.com  
Schaller Messtechnik GmbH  
Raab - Schallerstraße 99  
AT-8181 St. Ruprecht a.d. Raab  
www.humimeter.com | info@humimeter.com  
.....  
Bernhard Maunz  
Legal binding signature of the issuer

---

## 14.2 Technical data

Display resolution	Dependent on the sensor (see <a href="#">"Overview external sensors" page 3</a> )
Measuring range	Dependent on the sensor (see <a href="#">"Overview external sensors" page 3</a> )
Operating temperature	0 °C to +50 °C
Operating temperature insertion probe	0 °C to +40 °C
Operating temperature ram electrode	0 °C to +50 °C
Temperature measuring range	Dependent on the sensor (see <a href="#">"Overview external sensors" page 3</a> )
Storage temperature	-20 °C to +60 °C
Temperature compensation	Automatic
Data memory	Up to 10,000 measuring values
Power supply	4 pcs. of 1.5 Volt AA Alkaline batteries
Current consumption	60 mA (incl. display illumination)
Menu languages	English, German, French, Italian, Spanish, Portuguese, Czech, Polish, Russian, International
Display	128 x 64 illuminated matrix display
Device dimensions	145 x 65 x 27 mm
Device weight	250 g
Insertion probe dimensions	1,150 x 35 x 35 mm
Insertion probe weight	710 g
Ram electrode dimensions	360 x 45 x 45 mm
Ram electrode weight	1,500 g
Device IP rating	IP 40



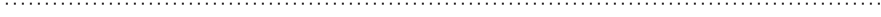
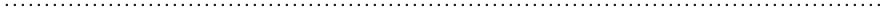
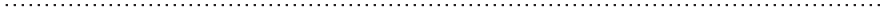

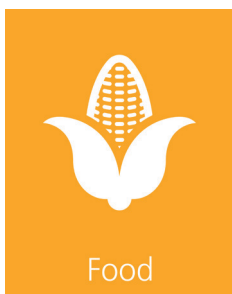
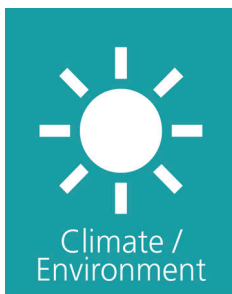

**GRUBATEC**



MESS- UND REGELTECHNIK

Gewerbehaus Ergolz, Wölferstrasse 5  
4414 Füllinsdorf

Telefon: +41 (0)55 617 00 80

Telefax: +41 (0)55 617 00 81

[www.grubatec.ch](http://www.grubatec.ch)

[sales@grubatec.ch](mailto:sales@grubatec.ch)