

Your BLC device at a glance

The main unit

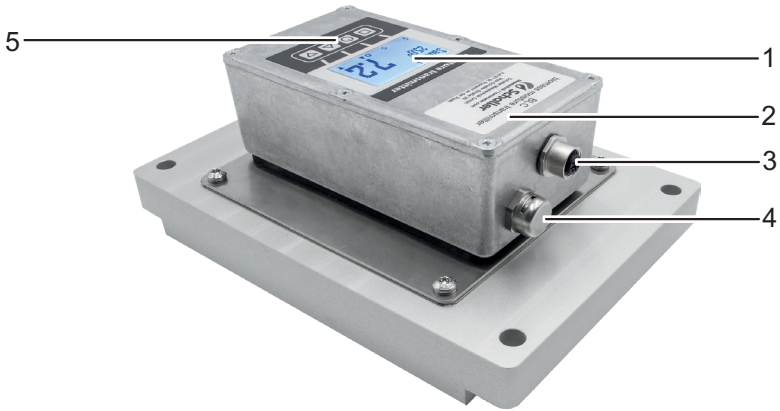

No.	Name
1	Display
2	Aluminium housing for electronics
3	Sensor plug
4	Pressure equalisation element
5	Keypad

Rear of the main unit

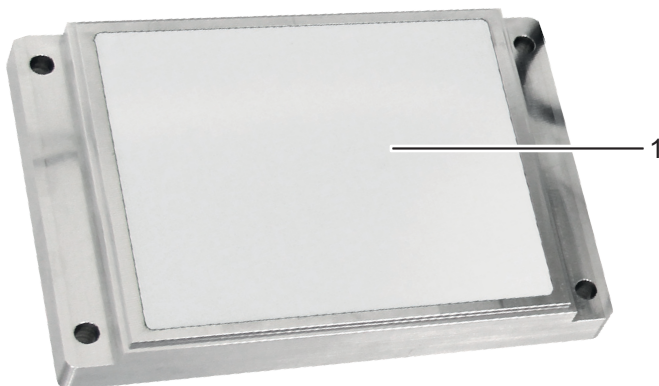

No.	Name
1	Sensor surface

The display

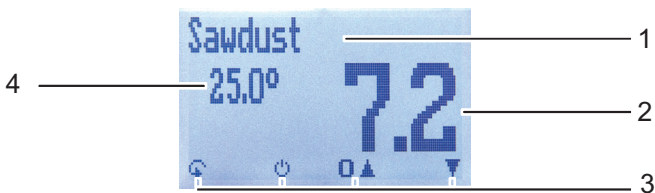

No.	Name
1	Calibration curve
2	Moisture content in % ("6.2 How moisture content is defined")
3	Display symbols
4	Temperature display

The display symbols

Symbol	Name
	Enter
	Up
	Down
	Back
	Enter numbers
	Enter letters
	Continue / go right

Symbol	Name
	Left
	Yes
	No
	Change input level
	OK
	Change menu
	On/off button

The menus

The device has two different menus: product selection and main menu:

Product selection menu

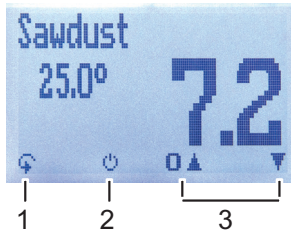

No.	Name
1	Change menu
2	Device on/off
3	For changing the calibration curve

Main menu

The main menu comprises the following menu items:

- **Adjust**
- **Options:**
Language, Unlock, °C/°F, Averaging, BL On Time, Material calibration, Password, Reset
- **Status**

Table of contents

Your BLC device at a glance	2
The main unit	2
The display symbols	4
The menus	5
1. Introduction	8
1.1 Information about this operating manual	8
1.2 Limitation of liability	8
1.3 Symbols used in this manual	9
1.4 Customer service	9
2. For your safety	10
2.1 Proper use	10
2.2 Improper use	10
2.3 User qualifications	10
2.4 General safety information	10
2.5 Warranty	11
3. On receipt of your device	11
3.1 Taking the device out of its packaging	11
3.2 Making sure that all of the components have been included	11
4. Installation of the moisture transmitter	12
4.1 Laying of the supply line or transmission line	12
4.2 Mounting the sensor	12
4.3 Pin assignment	13
4.4 Wiring diagram	14
5. Using the device - Basics	14
5.1 Selecting the calibration curve	14
5.2 Taking a measurement	14
6. Calibration curves	15
6.1 Selection of calibration curve for wood chips	16
6.2 How moisture content is defined	16
7. Checking the device's status	17
8. Configuring the device	18
8.1 Selecting a language	18
8.2 Activating options	18

8.3	Deactivating options	19
8.4	Selecting °C/°F	19
8.5	Setting the averaging time.....	20
8.6	Configuring the display illumination time	20
8.7	Configuring the material calibration function	21
8.8	Changing the password	21
8.9	Resetting the device to its factory settings	22
9.	Cleaning and maintenance.....	22
9.1	Care instructions	22
9.2	Cleaning the device	22
9.3	Adjusting the moisture transmitter	23
10.	Faults	24
11.	Storage and disposal.....	25
11.1	Storing the device	25
11.2	Disposing of the device	25
12.	Device information.....	26
12.1	CE declaration of conformity	26
12.2	Technical data	30
12.3	Technical drawing BLC.....	31

1. Introduction

1.1 Information about this operating manual

This operating manual is designed to enable you to use the BLC safely and effectively. It is part of the device, has to be stored nearby and must be easily accessible to users at all times.

All users are required to carefully read and make sure that they have understood this operating manual before using the BLC. All of the safety and operating instructions detailed in this manual have to be observed to ensure the safety of the device.

1.2 Limitation of liability

All of the information and instructions provided in this operating manual have been compiled on the basis of the current standards and regulations, the state of the art, and the extensive expertise and experience of Schaller Messtechnik GmbH.

Schaller Messtechnik GmbH does not accept any liability for damage associated with the following, which also voids the warranty:

- Non-observance of this operating manual
- Improper use
- Inadequately qualified users
- Unauthorised modifications
- Technical changes
- Use of unapproved spare parts

This fast measuring procedure can be affected by a range of different factors. For this reason, we recommend periodically checking the device's measurements with a standardised oven-drying method.

We, as the manufacturer, do not accept any liability for any incorrect measurements and associated consequential damage.

1.3 Symbols used in this manual

All of the safety information provided in this manual is shown with a corresponding symbol.



ATTENTION

It is essential to observe this warning. Non-compliance can lead to damage to property or equipment.



Information

This symbol indicates important information that enables users to use the device more efficiently and cost-effectively.

1.4 Customer service

For technical advice, please contact our customer service department at:

Schaller Messtechnik GmbH
Max-Schaller-Straße 99
A - 8181 St.Ruprecht an der Raab

Telephone: +43 (0)3178 28899
Fax: +43 (0)3178 28899 - 901

E-mail: info@humimeter.com
Internet: www.humimeter.com



© Schaller Messtechnik GmbH 2024

2. For your safety

The device complies with the following European directives:

- Restriction of Hazardous Substances in Electrical and Electronic Equipment (RoHS)
- Electromagnetic compatibility (EMC)

The device corresponds to state-of-the-art technology. However, it is still associated with a number of residual hazards.

These hazards can be avoided through strict observance of our safety information.

2.1 Proper use

- Online measurement of the water content (optionally water content and temperature) of wood chips, pellets, sawdust and other materials by installation of a sensor in the material flow
- Fully calibrated system with calculation of the measuring value by the transmitter unit

2.2 Improper use

- The device must not be used in ATEX.
- The installation location must be chosen in such a way that it is ensured that no condensation occurs in the sensor!

2.3 User qualifications

The device must only be operated by people who can be expected to reliably take the measurements. The device must not be operated by people whose reaction times may be slowed due to, e.g. the use of drugs, alcohol or medication.

All persons using this device must have read, understood and follow the instructions provided in the operating manual.

2.4 General safety information

The following safety information has to be observed at all times to avoid damage to objects and injury to people:

- In case of damages or loose parts on the device, contact Schaller Messtechnik GmbH or your dealer.

All of the device's technical features have been inspected and tested before delivery. Every device has a serial number. Do not remove the tag with the serial number.

2.5 Warranty

The warranty does not apply to:

- Damage resulting from non-observance of the operating manual
- Damage resulting from third-party interventions
- Products that have been used improperly or modified without authorisation
- Products with missing or damaged warranty seals
- Damage resulting from force majeure, natural disasters, etc.
- Damage from improper cleaning

3. On receipt of your device

3.1 Taking the device out of its packaging

- Take the device out of its packaging.
- Next, make sure that it is not damaged and that no parts are missing.

3.2 Making sure that all of the components have been included

Make sure that all of the components have been included by checking the package contents against the following list:

3.2.1 Scope of supply

- BLC
- Connecting cable of 1.9 m length
- Operating manual

Optional accessories:

- Analogue output for temperature measurement (-10 °C to +70 °C)

4. Installation of the moisture transmitter

4.1 Laying of the supply line or transmission line

- The cable must not be laid in the area of interference fields.
- Do not operate the transmitter in the area of electromagnetic interference fields.
- The cable must not be bent excessively.
- The permissible cross-sections for the installation must be observed.
- The cable length must be kept as short as possible.
- » If an extension of the cable is required, the cross-section of the extension must not be below 0.25 mm².

4.2 Mounting the sensor

- During the measurement, continuous contact between the sensor surface and the material being measured has to be ensured.
- For a correct measurement result, there must be a constant quantity of material to be measured in the measuring field of the sensor.
- There must be no contact of any conductive materials with the sensor surfaces.
- Mount the sensor on the four drilled holes (\varnothing 9.0 mm) .

Possible mounting locations:

- Bunker
 - » Installation at the side wall
- Screw conveyor
 - » **This mounting location is only possible for measuring sawdust!**
 - » Installation at the bottom of the trough
 - » There must be no windings above the sensor

4.3 Pin assignment

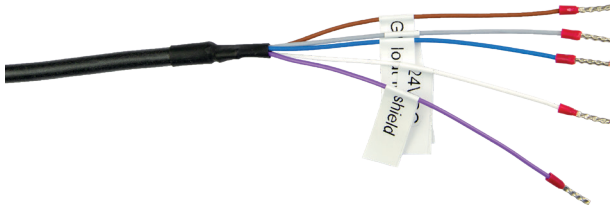

Cable color	Pin no.	Function
Brown	1	Power supply V- (0 VDC) Ground current output
White	2	Power supply V+ (24 VDC)
Blue	3	Analogue output humidity 4 - 20 mA
Black	4	n.c.
Grey	5	Analogue output temperature 4 - 20 mA (optional)
Purple	Housing	Equipotential bonding GND



ATTENTION

Damage to the electronics due to incorrect cable connection

Incorrectly connected cables can lead to severe damage of the electronics.

- ▶ Connect all cables correctly.

4.4 Wiring diagram

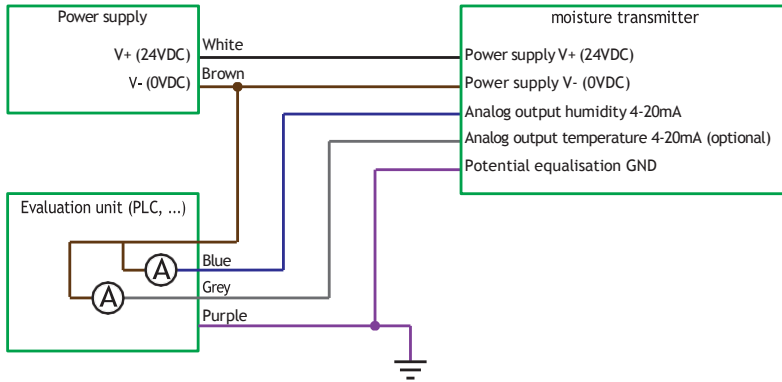





5. Using the device - Basics

5.1 Selecting the calibration curve

To do so: The device has to be in the product selection menu (figure 1).

For an overview of the different calibration curves and the criteria for selecting them, please refer to "6. Calibration curves"es".

1. Press the  or  button to move from one calibration curve to the next Or
2. Press the  or  button for 3 seconds to open the calibration curve overview (figure 2).
3. Use the arrow keys to move from one calibration curve to the next
4. and keep any of them pressed to scroll through the types.
5. Confirm your selection by pressing .

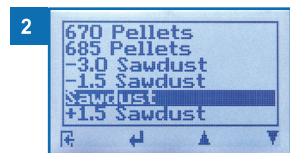
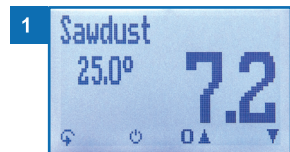

» The calibration curve you selected will now be shown at the top of the display.

5.2 Taking a measurement

- In order to obtain the currently measured values, the device has to be in the measuring window.

6. Calibration curves

Calibration curve	Material	Measuring range	Scaling Analog output
625 Pellets	Wood pellets with a bulk density of 625 kg/m ³	2 - 20%	0 to 20%
640 Pellets	Wood pellets with a bulk density of 640 kg/m ³	2 - 20%	0 to 20%
655 Pellets	Wood pellets with a bulk density of 655 kg/m ³	2 - 20%	0 to 20%
670 Pellets	Wood pellets with a bulk density of 670 kg/m ³	2 - 20%	0 to 20%
685 Pellets	Wood pellets with a bulk density of 685 kg/m ³	2 - 20%	0 to 20%
1 Sawdust	Sawdust with very high atro bulk density	2 - 60%	0 to 60%
2 Sawdust	Sawdust with high atro bulk density	2 - 60%	0 to 60%
Sawdust	Sawdust with medium atro bulk density	2 - 60%	0 to 60%
4 Sawdust	Sawdust with low atro bulk density	2 - 60%	0 to 60%
5 Sawdust	Sawdust with very low atro bulk density	2 - 60%	0 to 60%
-1 Woodchips	Fine wood chips with very high atro bulk density (fine and heavy hardwood)	2 - 60%	0 to 60%
0 Woodchips	Wood chips with very high atro bulk density (heavy hardwood)	2 - 60%	0 to 60%
1 Woodchips	Wood chips with high atro bulk density (hardwood)	2 - 60%	0 to 60%
2 Woodchips	Wood chips with medium atro bulk density (hardwood/softwood)	2 - 60%	0 to 60%
3 Woodchips	Wood chips with medium atro bulk density (hardwood/softwood)	2 - 60%	0 to 60%
4 Woodchips	Wood chips with low bulk atro density (softwood)	2 - 60%	0 to 60%

5 Woodchips	Wood chips with very low atro bulk density (light softwood)	2 - 60%	0 to 60%
6 Woodchips	Coarse wood chips with very low atro bulk density (coarse and light softwood)	2 - 60%	0 to 60%
Reference	! Only for testing the instrument !		
0% = 4mA	! Only for testing the instrument !		
60% = 20mA	! Only for testing the instrument !		

6.1 Selection of calibration curve for wood chips

The calibration curves for wood chips depends on the atro bulk density (bulk density at 0% water content), the wood type (hardwood, softwood), the size of the chips as well as on the content of fine fraction.

If you are not sure which calibration curve is the best suited for your material, it is recommended to carry out a reference measurement by kiln-drying (according to EN ISO 18134-2).

Schaller Messtechnik GmbH will be happy to advise you on the selection of the right calibration curve. Please send a picture of your wood chips, placing a measuring tape to the material, to support@schaller-gmbh.at. You will receive a recommendation from us immediately.

6.2 How moisture content is defined

The device measures and shows the material's moisture content. The moisture content readings it displays are calculated in relation to the material's overall mass:





$$\%WG = \frac{M_n - M_t}{M_n} \times 100$$

M_n : Mass of the sample with average moisture content

M_t : Mass of the sample with zero moisture content



%WG: Moisture content (in accordance with EN ISO 18134-2)

7. Checking the device's status

1. Press  twice or hold for 2 seconds.
2. Select **Status**. To do so, press  or  and confirm by pressing .
- » The display will then show the status indicator **humimeter**.
- » The display will show the following information:















No.	Name
1	Serial number
2	Software version
3	Battery status
4	Memory status

3. Confirm by pressing .
4. Press  to leave the main menu.











8. Configuring the device

8.1 Selecting a language



1. Press  twice or hold for 2 seconds.
2. Select **Options**. To do so, press  or  and confirm by pressing .
3. Select **Language**. To do so, press  or  and confirm by pressing .
4. Navigate to the required language. To do so, press  or  and confirm by pressing .
- » The settings have been saved.
5. Press  to leave the **Options** menu.
6. Press  to leave the main menu.

8.2 Activating options

To do so: Some of the options must be deactivated.

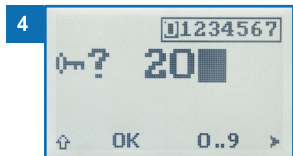
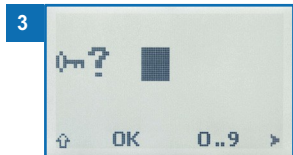
1. Press  twice or hold for 2 seconds.
2. Select **Options**. To do so, press  or  and confirm by pressing .
3. Select **Unlock**. To do so, press  or  and confirm by pressing .
- » The display will now appear as shown in figure 3.
- » On delivery, the four-digit password is the device's serial number.
4. **Inputting numbers:**
Press and hold  to quickly scroll to the required number and either press it for 3 seconds or press  to confirm the selected number (figure 4).
5. **Moving back:**
Press  to switch to another input level.
To move back, press .















-
6. Confirm the four-digit password by pressing **OK**.
 - » The setting has been saved.
 - » The **°C/°F**, **Averaging**, **BL On Time**, **Materialcalibration**, **Password**, **Reset** options are now activated
 7. Press  to leave the **Options** menu.
 8. Press  to leave the main menu.

8.3 Deactivating options

Once the device has been switched restarted, the **C/°F**, **Averaging**, **BL On Time**, **Materialcalibration**, **Password**, **Reset** options will be deactivated again.













8.4 Selecting °C/°F

To do so: All of the options must be activated (see "8.2 Activating options").

1. Press  twice or hold for 2 seconds.
2. Select **Options**. To do so, press  or  and confirm by pressing .
3. Select **°C/°F**. To do so, press  or  and confirm by pressing .
4. Navigate to the required temperature scale, i.e. Celsius (**°C**) or Fahrenheit (**°F**). To do so, press  or  and confirm by pressing .
- » The setting has been saved.
5. Press  to leave the **Options** menu.
6. Press  to leave the main menu.













8.5 Setting the averaging time

To do so: All of the options must be activated (see "8.2 Activating options").

1. Press  twice or hold for 2 seconds.
2. Select **Options**. To do so, press  or  and confirm by pressing .
3. Select **Averaging**. To do so, press  or  and confirm by pressing .
4. Navigate to the desired time period in which the arithmetic average should be calculated (90 seconds/45 seconds/20 seconds/7 seconds/ 5 seconds). To do so, press  or  and confirm by pressing .
 - » The setting has been saved.
5. Press  to leave the **Options** menu.
6. Press  to leave the main menu.

8.6 Configuring the display illumination time

To do so: All of the options must be activated (see "8.2 Activating options").









1. Press  twice or hold for 2 seconds.
2. Select **Options**. To do so, press  or  and confirm by pressing .
3. Select **BL On Time**. To do so, press  or  and confirm by pressing .
4. Navigate to the required setting, turned off (**0 Off**) or turned on (**1 On**). To do so, press  or  and confirm by pressing .
 - » The setting has been saved.
5. Press  to leave the **Options** menu.
6. Press  to leave the main menu.

8.7 Configuring the material calibration function

The type calibration function is described in a separate operating manual.

8.8 Changing the password



To do so: All of the options must be activated (see "8.2 Activating options").

1. Press  twice or hold for 2 seconds.
2. Select **Options**. To do so, press  or  and confirm by pressing .
3. Select **Password**. To do so, press  or  and confirm by pressing 
 - » The display will show the current password.
4. Overwrite the current password. To do so, press and hold **0..9** to quickly scroll to the required number and either press it for 3 seconds or press  to confirm the selected number.

Moving back:









Press  to switch to another input level.

To move back, press .

5. Confirm the new four-digit password by pressing **OK**.
 - » The setting has been saved.
6. Press  to leave the **Options** menu.
7. Press  to leave the main menu.

8.9 Resetting the device to its factory settings

To do so: All of the options must be activated (see "8.2 Activating options").

1. Press  twice or hold for 2 seconds.
2. Select **Options**. To do so, press  or  and confirm by pressing .
3. Select **Reset**. To do so, press  or  and confirm by pressing .
 - » The display will then show the message **Reset?** (figure 5).
4. Confirm by pressing .
 - » The device will now be reset to its factory settings. All of your personal settings will be lost.
 - » The display will show the status indicator **humimeter** (figure 6).
 - » Resetting the device will not affect the saved measuring values.

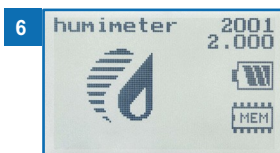
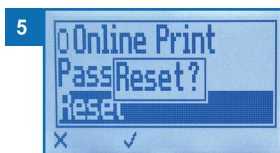

9. Cleaning and maintenance

Regularly cleaning and maintaining the device will ensure that it will have a long service life and stay in good condition.

9.1 Care instructions

- The moisture transmitter must be adjusted every four weeks.
- Do not immerse the sensor in water.
- Do not expose the device to extreme temperatures.
- Do not bend the sensor cable excessively. Repeated bending of the sensor cable can lead to a damage of the sensor.
- Protect the device from strong mechanical shocks and loads.

9.2 Cleaning the device







Sensor surface

Clean the sensor surface with a cloth and cleaning alcohol.

9.3 Adjusting the moisture transmitter

The moisture transmitter must be adjusted after installation and every four weeks during operation.

To do so: The moisture transmitter must be turned on for at least 30 minutes. There must be no material in the vicinity of the white sensor surface!

1. Press  twice or hold for 2 seconds.
2. Select **Options**. To do so, press  or  and confirm by pressing .
3. Select **Adjust**. To do so, press  or  and confirm by pressing .

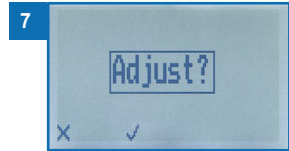

- » The display will then show the message **Adjust?** (figure 7).
- » **There must be no material in the vicinity of the white sensor surface!**
- » The temperature of the sensor should be similar to that during a measurement.

4. Confirm by pressing .

- » The display will now appear as shown in figure 8.
- » The bar will run upwards.
- » This will only take a couple of seconds to complete and when completed, the display will show the **Options** again.

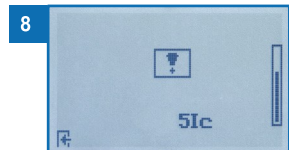

5. Press  and then  to leave the **Options** and the main menu.

10. Faults

If the measures listed below fail to remedy any faults or if the device has faults not listed here, please contact Schaller Messtechnik GmbH.

Fault	Cause	Remedy
Measuring error	The temperature of the material being measured is too low or high. I.e. the material's temperature is lower than 0 °C or higher than +50 °C.	The temperature of the material being measured has to be between 0 °C and +50 °C.
	Measurement error due to too short temperature adjustment time	Let the device adjust to the surroundings.
	Frozen material or material mixed with snow Accuracy decreases significantly	The material must not be frozen or mixed with snow.
	Mouldy or rain wet material Accuracy decreases significantly	Only measure dry, not mouldy material.
	Air value being displayed	If there is no material above the sensor, the air value will be displayed (2.0 %).
	Uneven pressure of the material	Make sure that the material applies even pressure onto the sensor.
	Polluted sensor	Clean the sensor surface (see "9.2 Cleaning the device").
	Conductive material on the sensor plates	Make sure that there is no contact of any conductive material with the sensor plates.
	The sensor plug is not connected correctly	Make sure that the sensor plug is connected properly.
Incorrect adjustment (the exclamation mark on the display does not go away)	There is an object/material in the vicinity of the white sensor surface (during calibration)	Remove any objects/materials in the vicinity of the white sensor surface.

11. Storage and disposal

11.1 Storing the device

The device must be stored as follows:

- Avoid mechanical shocks/loads
- Storage temperature: -20 °C to +60 °C

11.2 Disposing of the device



Devices marked with this symbol are subject to Directive 2012/19/EU of the European Parliament and of the Council of 4 July 2012 on waste electrical and electronic equipment (WEEE).

If the device is being operated outside the European Union, the national regulations on the disposal of such devices that apply in the country of use must be observed.

Electronic devices must not be disposed of as domestic waste.

The device must be disposed of appropriately using appropriate collection systems.

12. Device information

12.1 CE declaration of conformity

CE KONFORMITÄTSERKLÄRUNG DECLARATION OF CONFORMITY

Name/ Adresse des Herstellers: **Schaller Messtechnik GmbH**
Name/ address of manufacturer: **Max-Schaller-Straße 99**
A – 8181 St. Ruprecht

Produktbezeichnung: **Schaller**
Product designation:

Typenbezeichnung: **BRC ; BLC**
Type designation:

Produktbeschreibung: **Messgerät zur Bestimmung des Wassergehalts in Bio-
masse**
Product description **Measuring instrument for determining the water content in
biomass**

Das bezeichnete Produkt erfüllt die Bestimmungen der Richtlinien:
The designated product is in conformity with the European directives:

EMV - Richtlinie 2014/30/EC

EMC Directive 2014/30/EU

RoHS - Richtlinie 2011/65/EG

RoHS-Directive 2011/65/EU

Die Übereinstimmung des bezeichneten Produktes mit den Bestimmungen der Richtlinien wird durch die vollständige Einhaltung folgender Normen nachgewiesen:

Full compliance with the standards listed below proves the conformity of the designated product with the provisions of the above-mentioned EC Directives:

EN 61326–1:2013

Elektrische Mess-, Steuer-, Regel- und Laborgeräte - EMV-Anforderungen
Electrical equipment for measurement, control, and laboratory use – EMC requirements

EN IEC 63000:2019-05
ersetzt / replaced
EN 50581:2012

Technische Dokumentation zur Beurteilung von Elektro- und Elektronikgeräten hinsichtlich der Beschränkung gefährliche Stoffe.
Technical documentation for the assessment of electrical and electronic products with respect to the restriction of hazardous substances.

Für das angeführte Produkt ist eine vollständige Dokumentation mit Betriebsanleitung in Originalfassung vorhanden.

For the mentioned product a complete documentation with manual of instruction in original version is available.

Bei Änderungen, die nicht vom Hersteller spezifiziert sind, verliert diese Konformitätserklärung die Gültigkeit.

In case of any changes not agreed upon with the manufacturer, this declaration of conformity loses its validity.

St. Ruprecht a.d. Raab, 31.07.2022

 **Schaller**
Messtechnik / [juimper.com](http://www.juimper.com)
Schaller Messtechnik GmbH
1520 - Schaller / St. Ruprecht a.d. Raab
AT - 8195 St. Ruprecht a.d. Raab
www.juimper.com | info@juimper.com
.....
Bernhard Maunz
Rechtsverbindliche Unterschrift des Ausstellers
Legal binding signature of the issuer



DECLARATION OF CONFORMITY

Name/ address of manufacturer: **Schaller Messtechnik GmbH
Max-Schaller-Straße 99
A – 8181 St. Ruprecht**

Product designation: **Schaller**

Type designation: **BRC ; BLC**

Product description: **Measuring instrument for determining the water content in biomass**

The designated product is in conformity with the following directives:

- **Electromagnetic Compatibility Regulations 2016 Great Britain**
- **RoHS-Directive 2011/65/EU Directive on the restriction of the use of certain hazardous substances in electrical and electronic equipment**

Full compliance with the standards listed below proves the conformity of the designated product with the provisions of the above-mentioned Directives:

EN 61326–1:2013	Electrical equipment for measurement, control, and laboratory use – EMC requirements
EN IEC 63000:2019-05 replaced EN 50581:2012	Technical documentation for the assessment of electrical and electronic products with respect to the restriction of hazardous substances.

For the mentioned product, a complete documentation with manual of instruction in original version is available.

In case of any changes not agreed upon with the manufacturer, this declaration of conformity loses its validity.

St. Ruprecht a.d. Raab, 31.07.2022

 **Schaller**
Messtechnik / www.humimeter.com
Schaller Messtechnik GmbH
Raab - Schallerstraße 99
AT-8187 St. Ruprecht a.d. Raab
www.humimeter.com | info@humimeter.com
.....
Bernhard Maunz
Legal binding signature of the issuer

12.2 Technical data

Measuring range moisture content	2 % to 60 % (calibration curve dependent)
Measuring range temperature	-10 °C to +70 °C
Operating temperature	0 °C to +50 °C
Measuring depth	200 mm
Outputs	Moisture content (4 - 20 mA) -Scaling (0% to 60% Sawdust, Woodchips) -Scaling (0% to 20% Pellets) Temperature (4 - 20 mA) (optional) -Scaling (-10 °C to +70 °C) Working resistance < 500 Ohm (UB 24 V)
Temperature compensation	Automatic
Power supply	24 VDC (18 to 29 VDC)
Current consumption	50 mA (without output)
Electrical connection	Connecting cable 1.9 m
Menu languages	English, German, French, Italian, Spanish, Portuguese, Czech, Polish, Russian, International
Display	128 x 64 illuminated matrix display
Device dimensions	226 x 156 x 86 mm (without cable)
Device weight	2,500 g (without cable)
Device IP rating	IP 54

12.3 Technical drawing BLC

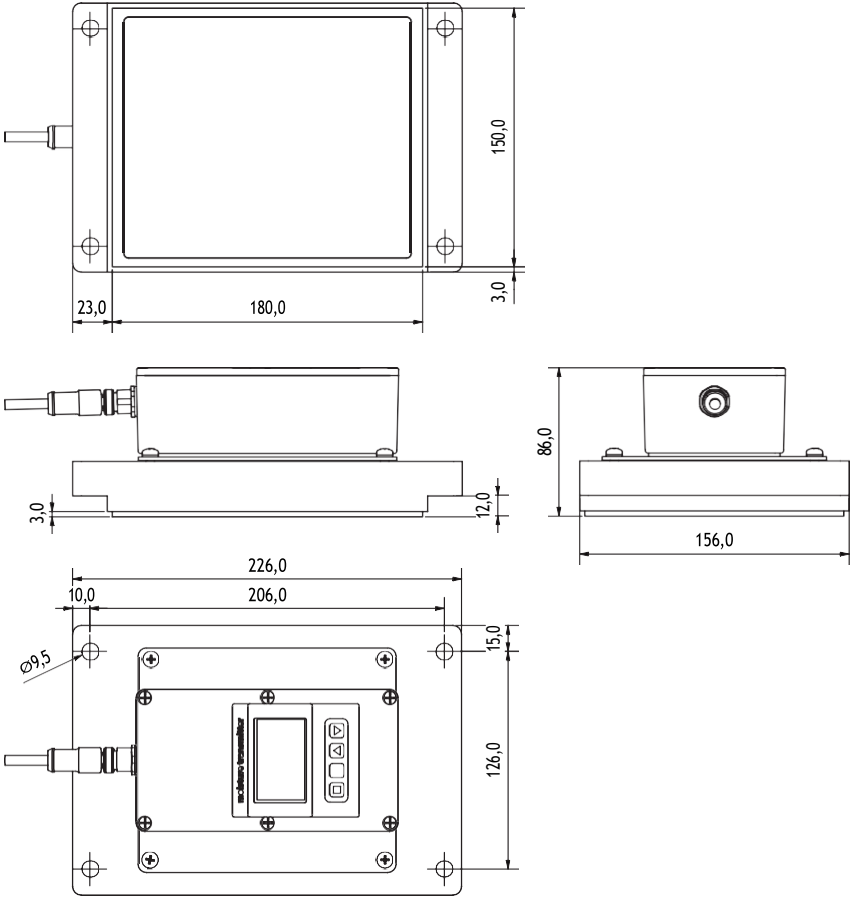

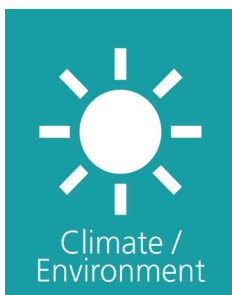

Gewerbehaus Ergolz, Wölferstrasse 5
4414 Füllinsdorf

Telefon: +41 (0)55 617 00 80

Telefax: +41 (0)55 617 00 81

www.grubatec.ch

sales@grubatec.ch