

Moisture meter

Instruction manual

LF-TD-E

Humidity transmitter series

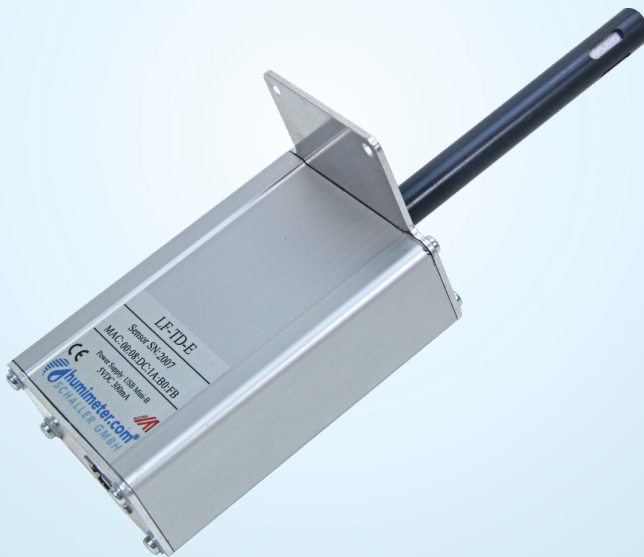

78.0°F | 6.16% | 456kg/m³ | -27.3td | 0.64aw | 51.9%r.H. | 14.8%abs | 100.4g/m² | 09m/s | 4.81m/s

Overview of your LF-TD-E

Overview of the basic unit

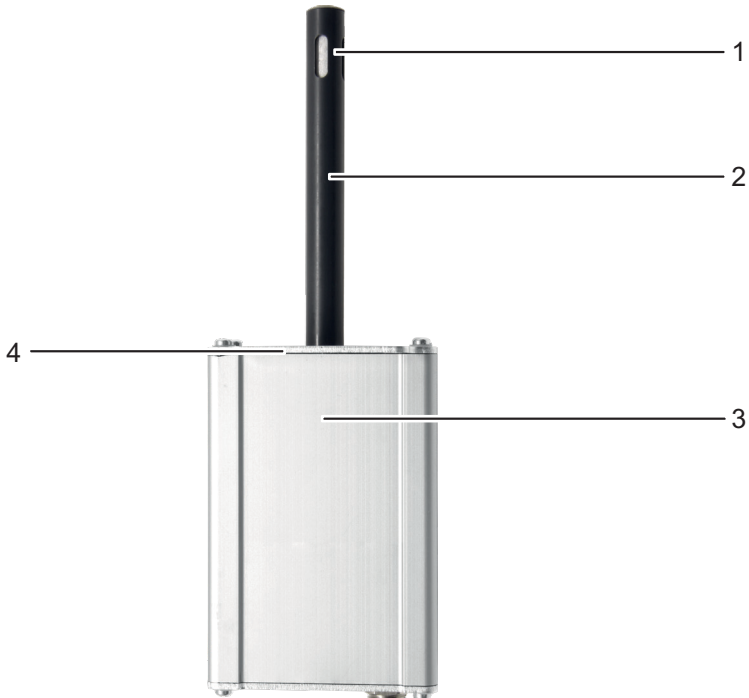

No	Description
1	Humidity and temperature sensor
2	Sensor tube
3	Aluminum housing
4	Fastening tab

Table of Contents

Overview of your LF-TD-E	2
Overview Basic unit	2
1. Introduction	5
1.1 Information about this instruction manual	5
1.2 Limitation of Liability	5
1.3 Symbols used	6
1.4 Customer Service	6
2. For your safety	7
2.1 Intended use	7
2.2 Improper use	7
2.3 Qualification of the operator	7
2.4 General Security	8
2.5 Warranty	8
3. Get started	8
3.1 Unboxing the device	8
3.2 Check the scope of delivery	9
3.2.1 Scope of Delivery	9
4. Installation of humidity & temperature transmitter	9
4.1 Laying of the supply or transmission line	9
4.2 Mounting the sensor tube	10
5. Find a transmitter	11
6. Technical drawing LF-TD-E	12
7. Alignment behavior of the sensor	13
8. Definition of humidity	14
8.1 Scope of use	14
9. Care and maintenance	15
9.1 Care instructions	15
9.2 Cleaning the device	15
10. Verification of calibration	16
10.1 Assembly of the calibration device	16
10.2 Determining the Variance	17
11. Disruptions	18
12. Storage and disposal	19

12.1	Store the device	19
12.2	Disposing of the device	19
13.	Information about the device	20
13.1	CE Declaration of Conformity	20
13.2	Technical Data	22
14.	Notes	23

1. Introduction

1.1 Information about this instruction manual

This instruction manual enables safe and efficient handling of the LF-TD-E. The operating instructions are an integral part of the device and must be kept in its immediate vicinity for the operator to access at all times.

The operator must have read and understood this instruction manual carefully before commencing any work. The basic prerequisite for safe working is compliance with all the safety instructions and instructions given in this operating manual.

1.2 Limitation of Liability

All information and information in this operating manual has been compiled taking into account the applicable standards and regulations, the state of the art and the many years of knowledge and experience of Schaller Messtechnik GmbH.

Schaller Messtechnik GmbH assumes no liability for damage in the following cases and the warranty claims expire:

- Failure to follow the instructions
- Unlawful use
- Insufficiently qualified operator
- unauthorized conversions
- Technical changes
- Use of non-approved spare parts

This rapid measurement method can be influenced by various boundary conditions.

As the manufacturer, we are not liable for any incorrect measurements and any consequential damage resulting from them.

1.3 Symbols used

Safety instructions are indicated by symbols in this user manual.



NOTE

Failure to do so can result in property damage.



Information

Identifies important information, the observance of which results in a more efficient and economical use.

1.4 Customer Service

For technical information, please contact our customer service:

Schaller Messtechnik GmbH
Max-Schaller-Straße 99
A - 8181 St.Ruprecht an der Raab



Phone: +43 (0)3178 28899
Fax: +43 (0)3178 28899 - 901

E-mail: info@humimeter.com
Internet: www.humimeter.com

© Schaller Messtechnik GmbH 2024



Information

Your purchased measuring device can be calibrated using suitable test ampoules / calibration ampoules and the adjustment can be checked. For this purpose, only use the calibration solutions sold by Schaller Messtechnik GmbH. For your test ampoules / calibration ampoules, you can download a calibration certificate under [https:// www.humimeter.com/certificates/](https://www.humimeter.com/certificates/) with the batch number printed on the ampoule.

2. For your safety

The device complies with the following European directives:

- Restriction of hazardous substances in electrical and electronic equipment (RoHS Directive)
- Electromagnetic compatibility (EMC Directive)

The device is built according to the latest state of the art. Nevertheless, there are residual dangers .

To avoid danger, you must follow the safety instructions.

2.1 Intended use

- Transmitter for the detection and transmission of relative humidity and temperature in fixed installations
- The sensor technology used makes it possible to detect even small humidity fluctuations and their tendencies quickly and reliably in order to enable preventive actions to be carried out.
- In some applications (e.g. duct installations) it is necessary to use a remote measuring probe for reasons of temperature adjustment.

2.2 Improper use

- The device must not be used in ATEX areas.

2.3 Qualification of the operator

Only persons who can be expected to carry out the work reliably are permitted to operate the device. Persons whose ability to react is affected, e.g. by drugs, alcohol or medication, are not admitted.

Persons using this device must have read and understood the user manual and follow its instructions.

2.4 General Security

Observe the following safety instructions to avoid personal injury and property damage :

- If you notice loose parts or damage to the device, contact your dealer.

Before your device is delivered, all technical characteristics have been checked and subjected to precise quality control. There is a serial number in each device. This sticker must not be removed.

2.5 Warranty

Excluded from the warranty:

- Damage caused by non-observance of the operating instructions
- Damage caused by third-party interventions
- Products that have been improperly used or altered without authorization
- Products where the warranty seal is missing or has been damaged
- Damage due to force majeure, natural disasters, etc.
- Damage due to improper cleaning

3. Get started

3.1 Unboxing the device

- Unpack the device.
- Immediately after unpacking, check the integrity and completeness of the device.

3.2 Check the scope of delivery

Check the list below to check the completeness of the delivery:

3.2.1 Scope of Delivery

- LF-TD E
- Optional

accessories:

- Mounting bracket for LF-TD
- Drip protection LF-TD
- Calibration certificates, calibration devices, humidity standards and reference devices - for ongoing monitoring

4. Installation of humidity & temperature transmitter

4.1 Laying of the supply or transmission line

- The line must not be laid in the area of interference fields.
- The transmitter must not be operated in the vicinity of electromagnetic interference fields.
- Permissible cross-sections for installation must be observed.
- The cable length must be kept as short as possible.
- When earthing the electronic housing and the display electronics, an appropriate equipotential bonding cable must be provided.

4.2 Mounting the sensor tube

- The measuring probe must be installed in a location that is representative for the measurement data recording.
 - » Avoid a position with draughts or unnatural temperature fluctuations.
 - » Furthermore, make sure that the device is not exposed to direct sunlight .
- If there is a risk of condensation, mount the sensor tube slightly upwards (approx. 10 degrees inclination).
 - » The condensation can thus run off the sensor tube in the direction of the housing or cable and drip off there.
 - » If an upward-inclined installation is not possible, a drip nose (optional accessory) must be fitted.
- Mounting in an air duct (or at installation locations where there may be temperature differences between the sensor tube and the sensor housing):
 - » To avoid a temperature gradient along the sensor tube, the sensor must be inserted into the opening in its entirety. See sketch:

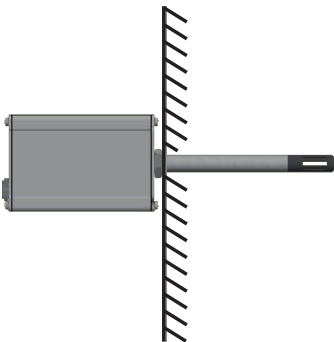

6. Technical drawing LF-TD-E

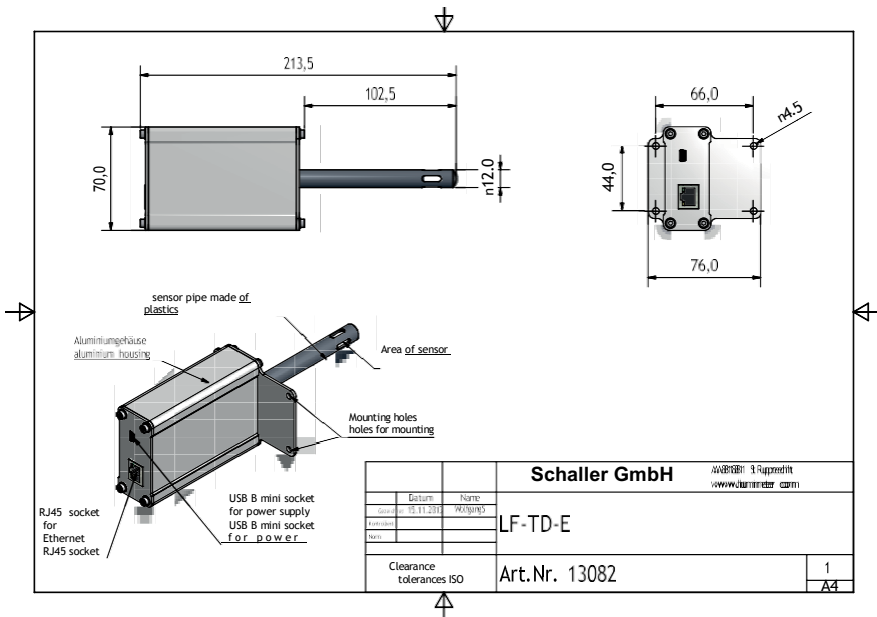

7. Alignment behavior of the sensor

In humidity and temperature measurement, several parameters are responsible for the adjustment behavior (time until the actual measured value is displayed). The parameter that can cause the largest measurement error is the temperature difference between the sensors or the entire measuring device and the material or air to be measured.

Therefore, let your device adjust until the displayed temperature corresponds to the actual temperature. The following diagram shows how long it takes to adjust from 20 °C to 30 °C.

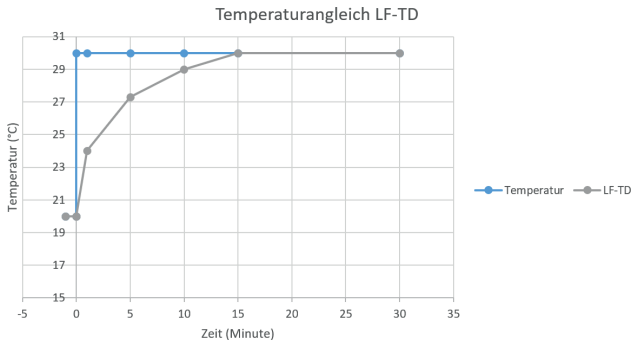

To illustrate the importance of temperature equalization between the measuring instrument and the object to be measured, here is a table for the measurement error for a temperature difference between the measuring instrument and the object to be measured of 1 °C / 1.8 °F at different ambient temperatures.

	10 °C (50 °F)	20 °C (68 °F)	30 °C (86 °F)
10 % RH	+/- 0,7 %	+/- 0,6 %	+/- 0,6 %
50 % RH	+/- 3,5 %	+/- 3,2 %	+/- 3,0 %
90 % RH	+/- 6,3 %	+/- 5,7 %	+/- 5,4 %

At room temperature (20 °C / 68 °F) and an assumed humidity of 50 % relative humidity, a temperature deviation of the sensor from the object to be measured of 1 °C / 1.8 °F results in an incorrect measurement of 3.2 % relative humidity. A deviation of 3 °C / 5.4 °F would cause a measurement error of over 10 % relative humidity.

8. Definition of humidity

The relative humidity indicates the ratio between the instantaneous water vapour pressure and the maximum possible, the so-called saturation vapour pressure.

The relative humidity shows the degree to which the air is saturated with water vapour. Examples:

50% relative humidity: At the current temperature and pressure, half of the air is saturated with water vapour. At 100% humidity, it would be completely saturated. If the air has more than 100% humidity; the excess moisture would condense or precipitate as fog.

8.1 Scope of use

The device operates within the specified accuracy in the normal range. Long-term use outside the normal range of application (max. range), especially with humidity above 80%, can lead to higher measurement deviations. When returning to the normal application range, the sensor returns to the specified accuracy by itself.

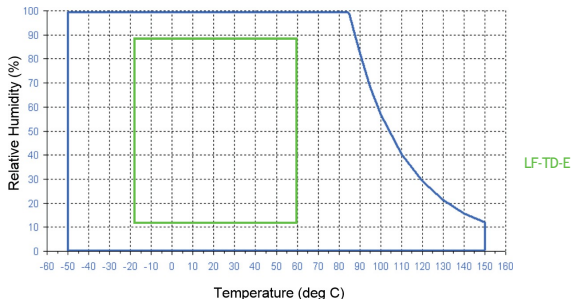

9. Care and maintenance

Regular cleaning and maintenance ensure that your device remains intact for as long as possible.

9.1 Care instructions

- Do not leave the device in the rain.
- Do not submerge the sensor in water.
- Do not expose the device to extreme temperatures.
- Avoid strong mechanical vibrations or loads.

9.2 Cleaning the device



NOTE

Damage or destruction of the sensor

Contact with water or cleaning agents can destroy the sensor.

- ▶ Carry out dry cleaning only.

Aluminum housing and sensor tube

Clean the aluminum housing and sensor tube with a dry cloth.

Air Humidity and Temperature Sensor

It is not possible to clean the humidity and temperature sensor. In the event of soiling, contact your dealer.

10. Verification of calibration

Prerequisite: Calibration device (item no. 10006) and humidity standard (item no. 10005). The device, as well as the calibration device and the calibration solutions, must have a temperature between 20.0 °C and 26.0 °C. It is recommended to store the device, as well as the calibration device and calibration solutions, in a room with low temperature fluctuations for 24 hours.

10.1 Assembly of the calibration device

1. Place the sealing ring over the thread of the lower part as shown in Figure 5 .
2. Place the textile pad in the lower part (Fig. 6) and carefully pour the moisture standard onto the pad, starting with the humidity standard 35% relative humidity.
3. Carefully place the top on top of the bottom (picture 7) and screw the top in a clockwise direction.

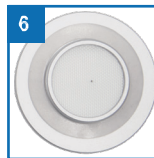

- » Recommendation: While screwing the upper part into place, leave the lower part on the table.
- » If necessary, lift the calibration device only straight up, do not tilt or turn it over.



4. Loosen the fastening nut counterclockwise until the sensor tube of the meter can be inserted without excessive pressure.
5. Now carefully push the sensor tube of the measuring device into the upper part until it stops (Figure 8).
6. Fix the calibration device to the sensor tube by screwing the previously loosened fastening nut into place.
 - » Make sure to lift the device with the calibration device only straight up and not to tip it over or turn it over. Otherwise, the sensor may be damaged.
 - » Leave the calibration device mounted on the sensor tube until explicitly stated otherwise.
 - » Place a spacer under the device so that the device and the calibrator lie horizontally on the table.



HINWEIS

Damage or destruction of the sensor

The sensor can be destroyed by tilting or turning the measuring device with the calibration device mounted.

- ▶ Achten Sie darauf, das Gerät nur gerade hochzuheben.

10.2 Determining the Variance

1. Allow the probe to adjust to the humidity standard for at least 2 hours.
2. Read the displayed humidity value and write it down together with the displayed temperature.
3. At ideal temperature conditions (measuring device, calibration device and calibration solution have 23 °C), the value printed on the humidity standard can be used as a reference value.
4. If there is a deviation from the factory temperature (23.0 °C), the real humidity value must first be determined according to the table below.

Temperature	Calibration Solutions		
	35 %	50 %	80 %
20 °C	34,6 %	49,8 %	79,9 %
21 °C	34,8 %	49,8 %	80,0 %
22 °C	34,9 %	49,9 %	80,0 %
23 °C	35,0 %	50,0 %	80,0 %
24 °C	35,1 %	50,1 %	80,0 %
25 °C	35,2 %	50,2 %	80,0 %
26 °C	35,4 %	50,2 %	80,1 %

5. Make a note of the real moisture value.
6. Compare the noted displayed value with the real moisture value.
 - » If the displayed value shows a deviation of less than 1.5 % relative humidity, it is recommended not to recalibrate.
 - » If the displayed value has a deviation of more than 1.5% relative humidity, contact your dealer in this case.
7. Now remove the calibration device from the sensor tube and repeat the work steps from point "[10.1 Installation of the calibration device](#)" either optionally with the humidity standard 50 % relative humidity or with the humidity standard 80 % relative humidity.

11. Disruptions

If the measures mentioned below do not remedy the faults or if other faults not listed here occur, please contact Schaller Messtechnik GmbH.

Disruption	Cause	Action
Incorrect measurement	Temperature out of range: below -20 °C or over +60 °C	Use the measuring device only for temperatures above -20 °C or below +60 °C.
	Measurement error due to too short temperature adjustment time	Allow the device to adjust to the environment for a sufficient amount of time (see "7).
	Heat or cold sources that do not correspond to the ambient temperature	Position your device in a new location that is representative of the indoor climate.
	Dripping water or sprayed water	Direct contact of the sensor with dripping water or sprayed water destroys the sensor.
	Irreversible impairment of the sensor element by aggressive gases	In this case, contact your dealer.
	Risk of condensation during temperature change	Condensation on the sensor will affect calibration . Allow the device to adjust to the ambient temperature.
	Dirty humidity sensor	In this case, contact your dealer.
	Foreign objects on the sensors	In this case, contact your dealer.

12. Storage and disposal

12.1 Store the device

Store your device under the following conditions:

- Do not store outdoors
- Store in a dry and dust-free place
- Protect from sunlight
- Avoid mechanical vibration/loads
- Storage temperature: -20 °C to +60 °C

12.2 Disposing of the device



The equipment marked with this symbol is subject to the European Directive 2012/19/EU of the European Parliament and of the Council of 4 July 2012 on waste electrical and electronic equipment.

If the device is not operated within the European Union, the national disposal regulations in the respective user country must be observed.

Electrical appliances do not belong in the household waste.

Dispose of the device in an environmentally friendly manner via suitable collection systems.

13. Information about the device

13.1 CE Declaration of Conformity

CE DECLARATION OF CONFORMITY DECLARATION OF CONFORMITY

Name/ Address of the manufacturer: **Schaller Messtechnik GmbH**

Name/ address of manufacturer: **Max-Schaller-Straße 99
A – 8181 St. Ruprecht**

Product name: **Schaller**

Product designation:

Type designation: **LF-TD-A ; LF-TD 60 ; LF-TD 90 ; LF-TD 120 ; LF-TD 150; LF
TD 180 ; LF-TD-E ; LF-TD-U ; LF-TD-ER ; LF-TD Profinet ;
LF-TD-H**

Type designation:

Product Description: **Measuring device for determining the relative humidity and
derived measurands**

Product description **Measuring instrument for determining relative humidity and
derived measured variables**

The designated product complies with the provisions of the Directives:

The designated product is in conformity with the European directives:

EMC Directive 2014/30/EC

EMC Directive 2014/30/EU

RoHS - Directive 2011/65/EC

RoHS Directive 2011/65/EU

The conformity of the designated product with the provisions of the Directives is demonstrated by full compliance with the following standards:

Full compliance with the standards listed below proves the conformity of the designated product with the provisions of the above-mentioned EC Directives:

EN 61326-1:2013

Electrical Measuring, Control, Regulation and Laboratory
Equipment - EMC Requirements
*Electrical equipment for measurement, control, and laboratory
use – EMC requirements*

EN IEC 63000:2019-05

replaced

EN 50581:2012

Technical documentation for the assessment of electrical and
electronic equipment with regard to the restriction of hazardous
Substances.
*Technical documentation for the assessment of electrical and
electronic products with respect to the restriction of hazardous
substances.*

For the listed product, complete documentation with operating instructions is available in the original version.

For the mentioned product, a complete documentation with manual of instruction in original version is available.

In the event of changes not specified by the manufacturer, this declaration of conformity loses its validity.

In case of any changes not agreed upon with the manufacturer, this declaration of conformity loses its validity.

St. Ruprecht a.d. Raab, 31.07.2022



Schaller
Messtechnik / Humidimeter.com
Schaller Messtechnik GmbH
Maier - Schaller 37400 99
AT - 8150 St. Ruprecht a. Raab
www.humidimeter.com | info@humidimeter.com

Bernhard Maunz
Legally binding signature of the issuer
Legal binding signature of the issuer

13.2 Technical data

Measuring range of relative humidity	0% to 100%
Calibration of relative humidity	10% to 90%
Measuring range temperature	-20 °C to +60 °C
Calibration Temperature	+10 °C to +60 °C
Accuracy Temperature	+/- 0.3 °C
Accuracy Humidity	+/- 2 %
Output	Connector RJ45 (Ethernet)
Supplies	5VD 300 mA via USB Mini B Female
Dimensions	214 x 76 x 70 mm
Material housing	Anodized aluminum
Dimensions sensor tube	12 x 102.5 mm
Material Sensor Tube	Plastic
Sensor cap	Plastic with filter paper
Degree of protection for electronic housings	IP 40



Gewerbehaus Ergolz, Wölferstrasse 5
4414 Füllinsdorf
Phone: +41 (0)55 617 00 80
Fax: +41 (0)55 617 00 81
www.grubatec.ch
sales@grubatec.ch