

Instruction manual Technical description

Humidity transmitter series

LF-TD-U



Version 1.1

© Messtechnik Schaller GmbH
2013

Max-Schaller-Straße 99
A – 8181 St. Ruprecht an der Raab
Tel +43 (0)3178 28899
Fax +43 (0)3178 28899 - 901
support@schaller-gmbh.at
<http://www.humimeter.com/>

Humidity - Temperature Transmitter

Transmitter for the detection and transmission of relative humidity and temperature in fixed installations.

Input voltage 5VDC via USB mini-B.

The sensor technology used makes it possible to detect even small humidity fluctuations and their tendencies quickly and reliably in order to enable preventive actions to be carried out. In some applications (e.g. duct installations) it is necessary to use a remote measuring probe for reasons of temperature adjustment.

The inspection of the adjustment and its intervals are based on the required accuracy requirements in the area of application and the stress.

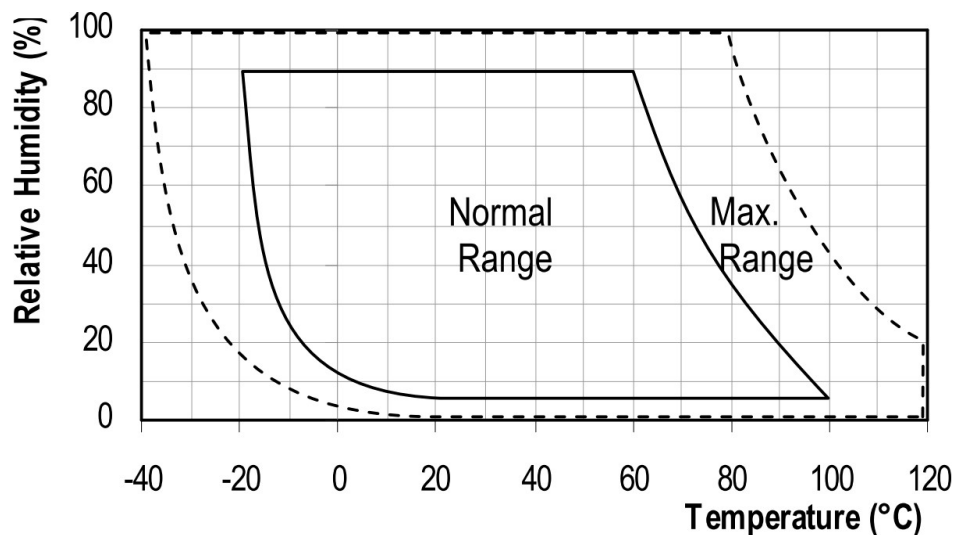

Relative humidity:

Indicates the ratio between the instantaneous water vapor pressure and the maximum possible, the so-called saturation vapor pressure.

The relative humidity shows the degree to which the air is saturated with water vapour. Examples:

50% relative humidity: At the current temperature and pressure, half of the air is saturated with water vapour. At 100% humidity it would be completely saturated. If the air has more than 100% humidity, the excess moisture would condense or precipitate as fog.

Common causes of incorrect measurements

The accuracy of the measurement results depends on a variety of factors. Here is a list of the most common sources of error:

- Risk of condensation in the event of temperature changes (from cold to warm)
- Exposure to sunlight or other sources of heat or cold that do not correspond to the ambient temperature
- Irreversible impairment of the sensor element by aggressive gases
- Dripping water or sprayed water
- Contamination of the sensor element by dust or salts
- No checking of the adjustment during operation
- Measurement error due to too short adjustment time

The Next Table shows the Measurement deviation at a temperature difference of 1°C:

Rel. F	10°C	20°C	30°C
10%	±0.7%	±0.6%	±0.6%
50%	±3.5%	±3.2%	±3.0%
90%	±6.3%	±5.7%	±5.4%

Explanation: At room temperature and assuming 50% RH.

F. If the temperature deviation of the sensor from the object to be measured is 1°C, an incorrect measurement of 3.2% relative humidity results. A deviation of 3°C results in an incorrect measurement of over 10% rel. F.!

Installation of the humidity temperature transmitter

- The cable for supply or transmission must not be laid in the area of interference fields.
- Observe permissible cross-sections for installation
- Basically, it is important to keep the cable length as short as possible.
- Likewise, the transmitter must not be operated in the vicinity of electromagnetic interference fields!
- If the electronic housing and the display electronics are earthed, an appropriate equipotential bonding cable must be provided.

Sensor head mounting:

The Measuring probe must be on a for the Measured value recording can be attached to a representative location.

If there is a risk of condensation, the sensor head must be mounted slightly upwards so that the condensation can run away from the sensor head (sensor cap) towards the housing or cable and drip off there.

Disclaimer

As the manufacturer, we are not liable for any incorrect measurements and any damage resulting from them.

Since this measurement method can be influenced by product- and application-specific boundary conditions, it is advisable to carry out a plausibility check of the measured values. There is a serial number and a warranty seal in each device. If this is broken, no warranty claims can be asserted.

In the event of a defect, please contact Schaller GmbH at www.humimeter.com or a dealer.

Technical data

Type	LF-TD-U
Item No.	13083
Measuring range	
Relative humidity	0 to 100 %
Temperature	-20°C to +60°C
Output	
Plug connection	USB mini-B socket
Factory Calibration Accuracy	
Relative humidity	10 to 90%: ± 2.0%
Temperature	+10 to +60°C: ± 0.3 °C
Operating temperatures	
Sensor head	-20°C to +60°C
Electronics	-20°C to +85°C
Supplies	
Voltage	5VDC
Current consumption	approx. 20 mA
Dimensions and Miscellaneous	
Sensor head dimensions	Ø 12 x 102.5 mm
Sensor head material	Plastic
Dimensions electronics housing	70 x 32 x 120 mm
Dimensions LF-TD-U	214 x 76 x 70 mm
Material Electronics Housing	Anodized aluminum
Degree of protection for electronic housings	IP 40
Electrical connection	USB mini-B socket

Technical Drawing LF-TD-U

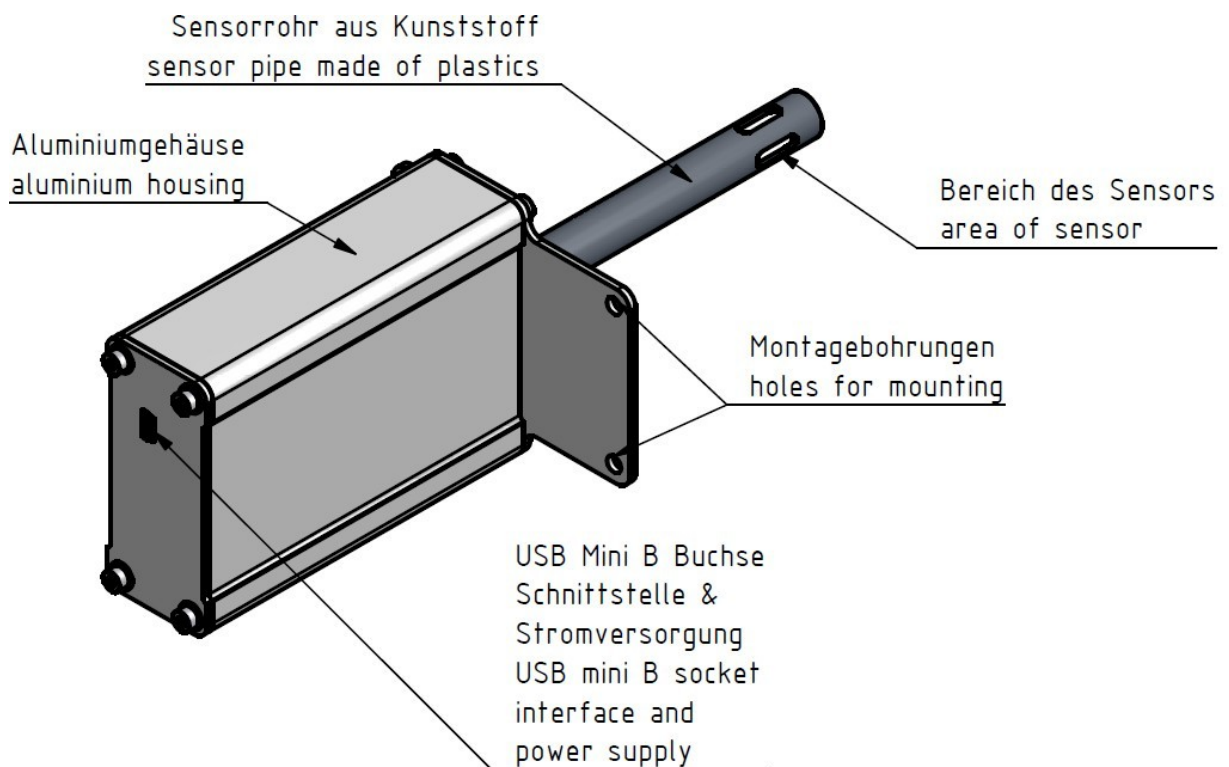
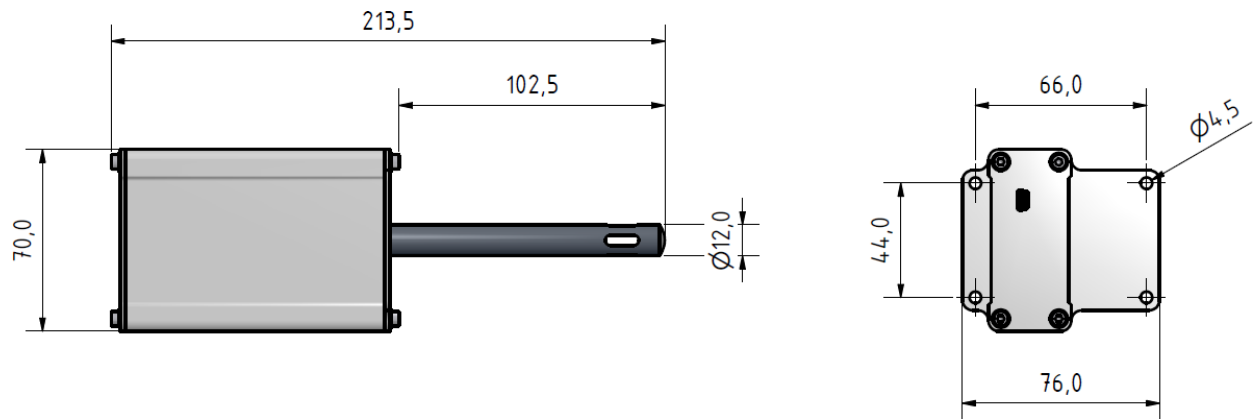

(no original illustration, depending on the type version-related deviations).

Calibration Accessories:

Calibration certificates, calibration devices, relative humidity standards 35, 50, 80 %, or reference devices for ongoing monitoring available on request.

IMPORTANT!

Common causes of incorrect measurements

- ***Risk of condensation in the event of temperature changes (from cold to warm)***
- ***Exposure to sunlight or other sources of heat or cold that do not correspond to the ambient temperature***
- ***Irreversible impairment of the sensor element by aggressive gases***
- ***Dripping water or sprayed water***
- ***Contamination of the sensor element by dust or salts***
- ***Measurement error due to too short adjustment time***
- ***Foreign objects on the sensors***



Gewerbehaus Ergolz, Wölferstrasse 5

4414 Füllinsdorf

Phone: +41 (0)55 617 00 80

Fax: +41 (0)55 617 00 81

www.grubatec.ch

sales@grubatec.ch