



- ❑ Diaphragm element
- ❑ Measuring range 0...50 Pa to 0...6000 Pa
- ❑ 4 calibrated measuring ranges selectable via DIP-switch
- ❑ Analog output signal 0...10 V
- ❑ Supply voltage 15...30 Vdc or 24 Vac (±15%)
- ❑ Compact plastic housing IP 65; UL 94 HB

The differential pressure sensor DS85-P...E is used to measure small differential pressures in ventilation and air conditioning.

The measurement range from 0...50 Pa up to 0...6000 Pa is divided in three measurement groups. Each group has four calibrated measurement ranges, which are selectable by two DIP-Switches.

**PERFORMANCE:**

Overload protection: 0.2 bar  
 Static pressure: max. 0.2 bar  
 Zero point calibration: Adjustable by REEDcontact, no cyclic zero-point calibration required  
 Reaction time: direct

**ACCURACY / ERROR LIMIT:**

Zero drift: See table: Error limits  
 Sum of linearity and hysteresis: See table: Error limits  
 Temperature drift measuring range: Because 4 measuring ranges in 3 measuring groups

**TECHNICAL SPECIFICATIONS:**

Operating mode: Measuring mode  
 Measuring medium: Air or non-aggressive gases  
 Measuring principle: Electromechanical diaphragm measuring system  
 Measuring unit: Pa  
 Smallest measuring range: 0...50 Pa (0.5 mbar)  
 Largest measuring range: 0...6000 Pa (60 mbar)  
 Measuring range: 0...50 Pa (0.5 mbar), 0...200 Pa (2 mbar), 0...500 Pa (5 mbar), 0...1000 Pa (10 mbar), 0...2000 Pa (20 mbar), 0...4000 Pa (40 mbar), 0...6000 Pa (60 mbar)  
 Measuring range selection: yes via 2-pole DIP switch  
 Characteristic: linear  
 Ambient temperature: -20...+60 °C  
 Storage temperature: -30...+70 °C

**PHYSICALLY:**

Housing: UL 94 HB; Ultramid with hinged lid of ABS  
 Dimensions: 95 x 70 x 54 mm (w x h x d)  
 Weight: approx. 250 g  
 Protection class: IP65 according to DIN EN 60529/VDE 0470 Part 1: 2014  
 Electrical connections: cable entry M16x1.5, screw terminals, electronics protected against incorrect polarity  
 Pressure connections: hose connections 5 mm ø and 6 mm ø  
 Operational position: vertical, position dependence when rotated through 90° approx. 25 Pa

**ELECTRONIC:**

Power supply: 15...30 Vdc or 24 Vac ± 15 %  
 Power consumption: approx. 5 mA at 15 Vdc; approx. 12 mA at 30 Vdc  
 Output: 0...10 V three-wire circuit

**CONFORMITY:**

EMC: EN 61000-6-2, EN 61000-6-3, CE-mark  
 RoHS: According RoHS-directive 2011/65/EU

### Error limits (related to the actual range)

	Zero deviation	Final value deviation	Linearity	Resolution	Hysteresis
<b>DS85-P200E</b>					
0...200 Pa	± 0.5 %	± 0.5 %	± 0.25 %	0.1 %	1 %
0...150 Pa	± 0.75 %	± 0.6 %	± 0.4 %	0.2 %	0.7 %
0...100 Pa	± 1 %	± 0.7 %	± 0.5 %	0.2 %	0.5 %
0...50 Pa	± 2 %	± 1 %	± 1 %	0.3 %	0.5 %
<b>DS85-P1000E</b>					
0...1000 Pa	± 0.5 %	± 0.5 %	± 0.25 %	0.1 %	0.2 %
0...500 Pa	± 0.7 %	± 0.7 %	± 0.5 %	0.2 %	0.2 %
0...300 Pa	± 0.9 %	± 0.9 %	± 0.9 %	0.3 %	0.2 %
0...200 Pa	± 1 %	± 1 %	± 1.25 %	0.3 %	0.2 %
<b>DS85-P6000E</b>					
0...6000 Pa	± 0.5 %	± 0.5 %	± 0.25 %	0.1 %	0.2 %
0...4000 Pa	± 0.7 %	± 0.7 %	± 0.4 %	0.15 %	0.2 %
0...3000 Pa	± 0.9 %	± 0.9 %	± 0.6 %	0.2 %	0.2 %
0...2000 Pa	± 1 %	± 1 %	± 0.75 %	0.25 %	0.2 %

### Temperature drift (based on the highest measuring span)

Zero point	± 0.2 % / K
End value	± 0.3 % / K

### Connections

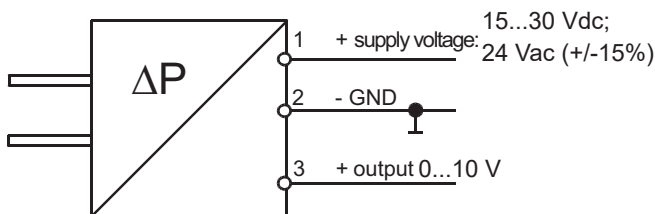

### Dimensions (mm)

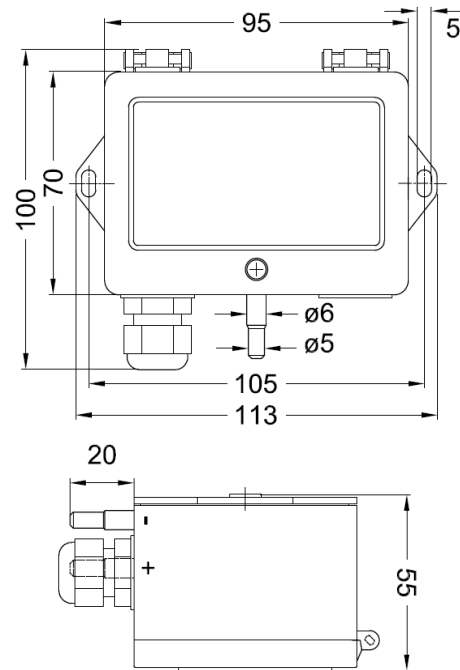

### Item no.

#### Differential pressure sensor DS85-P200E

2555

Output: 0...10V, 3-wire technology  
Range: 0...200, 0...150, 0...100, 0...50 Pa

#### Differential pressure sensor DS85-P1000E

2556

Output: 0...10V, 3-wire technology  
Range: 0...1000, 0...500, 0...300, 0...200 Pa

#### Differential pressure sensor DS85-P6000E

2557

Output: 0...10V, 3-wire technology  
Range: 0...6000, 0...4000, 0...3000, 0...2000 Pa

### ACCESSORIES

Mounting set M-DS with screws, bleeder Connections and 2 m plastic hose (4 x 1.5 mm)

25305