

Non-Contact Temperature Measurement

DIGITAL – INFRARED – PYROMETER

Temperature range 250 to 2500°C (482 - 4532°F)

**Temperature control during production process
compact units – Infrared – measuring transducer and electronic process
unit in one case with light beam aiming device
or optical viewfinder, focusable optic,
serial interface, limit output**

Series KTRD 1075



Infrared – pyrometer can also assist you to monitor your heating processes, ensuring a uniform standard of quality for your products.

leaflet KTRD 1075

Dr. Georg Maurer GmbH
-Optoelektronik-

GRUBATEC



MESS- UND REGELTECHNIK

Grubatec AG
Wölferstrasse 5
4414 Füllinsdorf
Telefon: +41 (0)55 617 00 80
Telefax: +41 (0)55 617 00 81
www.grubatec.ch
sales@grubatec.ch

Infrared-Digital-Pyrometer Series KTRD 1075

More than 60 years experience in the area of non-contact temperature measurement and permanently development of the pyrometers makes it possible to offer you a complete program of field tested units..
Mainly for **fast warming processes** the **contactless temperature measurement** is suitable.

The **series KTRD 1075** are **digital part radiation pyrometer** with vario-objective in compact structure likewise suitable for industry, research and laboratory.

With the integrated light beam aiming device (green LED or Laser) resp. viewfinder an adjusting of the pyrometer to the measuring object is very easy.

The temperature linear analog output signal 0/4 up to 20 mA is available for measuring- and controlling purposes.

The simultaneous using of the serial interface with the software IR-LOG enables the data detection, graphical representation and the parameter settings of the pyrometer.

Examples for applications:

steel, iron, non-ferrous metal, tempering, coating, wires, hardening, induction heating, soldering, forging, pre-heating, rolling, glowing etc.

Technical datas:	
Unit types	KTRD 1075-1
Target marking	light beam aiming device green LED or laser
Temp. measuring ranges:	MR 1: 250 - 1400°C 482 - 2552°F
Response time (t90)	<0,5 ms
Spectral range	1,45 - 1,7 μm
Measuring uncertainty	0,5% of meas.value in °C ± 1°C (ε = 1, T _{amb.} = 23°C, T ₉₅ = 1s)
Reproducibility	0,1% of meas.value in °C ± 1°C (ε = 1, T _{amb.} = 23°C, T ₉₅ = 1s)
Emission factor ε	100 - 10 % adjustable at the unit or through interface
Analog output	0 - 20 mA or 4 - 20 mA , load max. 500R
Part measuring ranges:	free adjustable within the measuring range
Resolution	< 0,1% analog output, < 0,1°C at interface
1 limit output (open coll.)	24 V DC / max. 100 mA
Max.reading memory	max.memory, double memory,adjustable time and threshold value, erasing after time, external contact, by software, after new meas.part
Interface	RS 232 isolated ± 50 V or RS 485 isolated 2500VRMS options: PROFIBUS, PROFINET, Ethernet, EtherCAT, USB 2.0
Software IR-LOG	data recording, graph.representation, setting of pyrometer parameters
adjustable parameter with Software IR-LOG	emissionfactor,switching output,analog output, part meas.range, °C/°F, max.memory, average value, light beam aiming device switchable
Objectives	for accommodation to the measuring application an extensive selection of objectives are available
Working temperature	pyrometer 0 - 50°C (32-122°F), optic system up to 150°C(302°F)
Stock temperature	- 10°C - + 70°C (14-158°F)
Temperature sensitivity	0,05 % / °C
Humidity tolerance	35 - 85 % RF (non condensing)
Operating voltage	24 V DC ± 10 % or 18 V AC ± 10 % < 160 mA
Unit connection	12-pole plug-connector
Dimensions: H / W / D	54 x 54 x 147 mm (2,13 x 2,13 x 5,79 inch) ALU-case
Weight	0,6 kg (1,32 lbs)
Protection grade	IP 65
Option	built in digital display

mechanical assembly	electrical assembly	
Execution in cooling case	AED 1012	electr.process unit
Blowing device	AED 1012-C	PID controller
Mirror 90°	AED 1012-PC	Program controller
Mounting parts	power supply 100-270VAC - 24 VDC	digital display (built in-execution) connection cable 12-pole line scanner SC 1000 / SC 1012 PC-Box (USB – connection set)

Optic tables for KTRD 1065+1075+1085 and QKTRD 1075+1085

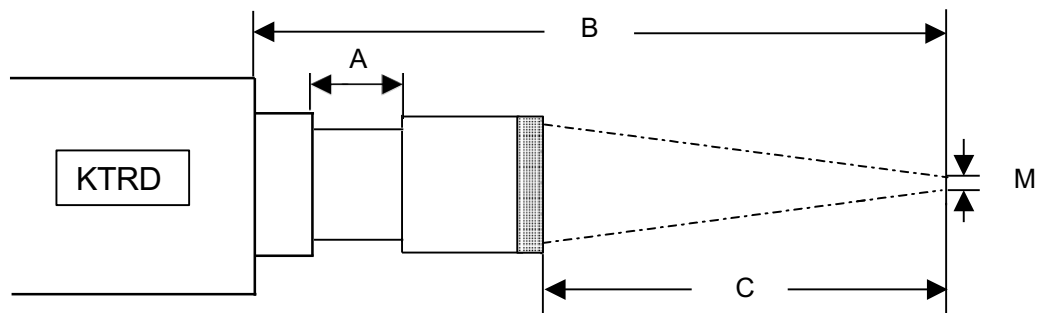

Optic-type : L 1050-N1			
Lens : f 50 22,4 ∅			
Meas. aperture : 0,5 mm ∅			
Meas. distance from casing of meas. head B / mm	Meas. distance from optic front edge C / mm	Optic extension A / mm	Target size M / mm=d
180	124	13	1,5
190	137	10	1,6
200	149,5	7,5	1,7
210	162	5,0	1,8
220	173,5	3,5	1,9
230	185	2,0	2,0
240	196	1,0	2,1
250	207	0	2,2

Optic-type : L 1060-N1			
Achromat : f 60 22,4 ∅			
Meas. aperture : 0,5 mm ∅			
Meas. distance from casing of meas. head B / mm	Meas. distance from optic front edge C / mm	Optic extension A / mm	Target size M / mm=d
285	229	13	1,5
300	245,4	11,6	1,6
350	299,9	7,1	1,9
400	352,3	4,7	2,3
450	404,1	2,9	2,7
500	455,5	1,5	3,2
550	507	0	3,8

Optic-type : L 1050-N2			
Lens : f 50 22,4 ∅			
Meas. aperture : 0,5 mm ∅			
Meas. distance from casing of meas. head B / mm	Meas. distance from optic front edge C / mm	Optic extension A / mm	Target size M / mm=d
210	154,0	13,0	1,3
220	166,1	10,9	1,4
240	188,6	8,4	1,6
260	210,9	6,1	1,8
280	232,6	4,4	2,1
300	253,9	3,1	2,3
320	274,9	2,1	2,5
340	295,5	1,5	2,7
360	316,0	1,0	2,9
380	336,5	0,5	3,1
400	357,0	0,0	3,3

Optic-type : L 1060-N2			
Achromat : f 60 22,4 ∅			
Meas. aperture : 0,5 mm ∅			
Meas. distance from casing of meas. head B / mm	Meas. distance from optic front edge C / mm	Optic extension A / mm	Target size M / mm=d
350	294	13	2,0
400	346,7	10,3	2,4
450	398,9	8,1	2,8
500	450,1	6,9	3,2
550	501,1	5,9	3,7
600	522	5,0	4,2
650	603	4,0	4,7
700	653,9	3,1	5,2
750	704,4	2,6	5,6
800	754,9	2,1	6,1
1000	956,2	0,8	9,2

Target=98 % of beam density of the surface

Optic tables for KTRD 1065+1075+1085 and QKTRD 1075+1085

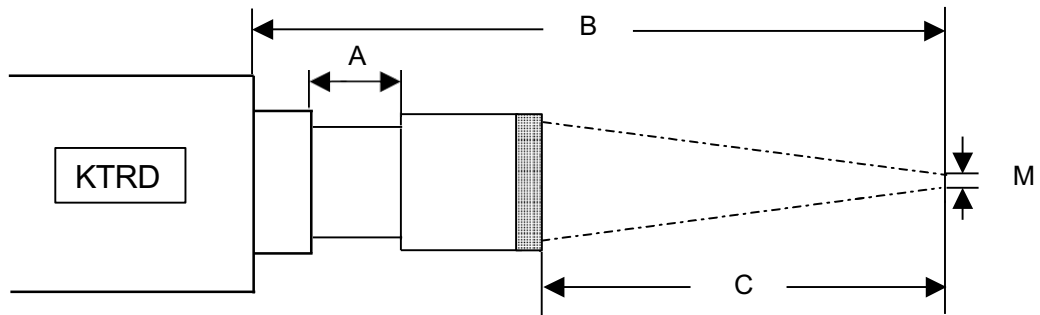

Optic-type	: L 1060-T		
Achromat	: f 60 22,4 \varnothing		
Meas. aperture	: 0,5 mm \varnothing		
Meas. distance from casing of meas. head B / mm	Meas. distance from optic front edge C / mm	Optic extension A / mm	Target size M / mm=d
335	279	13	2,6
400	345,8	11,2	2,5
500	448,5	8,5	3,2
600	550	7,0	4,0
700	651,4	5,6	4,8
800	753	4,0	5,9
900	853,9	3,1	7,2
1000	954,8	2,2	8,3
2000	1956	1,0	14,6
3000	2955,4	0,6	23,9
4000	3956,8	0,2	31,0

Optic-type	: A 1080		
Achromat	: f 80 31,5 \varnothing		
Meas. aperture	: 0,5 mm \varnothing		
Meas. distance from casing of meas. head B / mm	Meas. distance from optic front edge C / mm	Optic extension A / mm	Target size M / mm=d
620	557,5	13	3,5
700	639,9	10,6	4,0
800	741,4	9,1	4,5
900	842,5	8,0	5,0
1000	943,4	7,1	6,0
1100	1044,3	6,2	6,5
1200	1144,9	5,6	7,0
1300	1245,4	5,1	7,5
1400	1345,8	4,7	8,0
1500	1446,2	4,3	8,5
1600	1546,5	4,0	9,2
1700	1646,9	3,6	10,0
1800	1747,2	3,3	10,8
1900	1847,4	3,1	11,5
2000	1947,5	3,0	12,1
3000	2948,5	2,0	18,0
4000	3949,2	1,3	24,0

Target=98 % of beam density of the surface

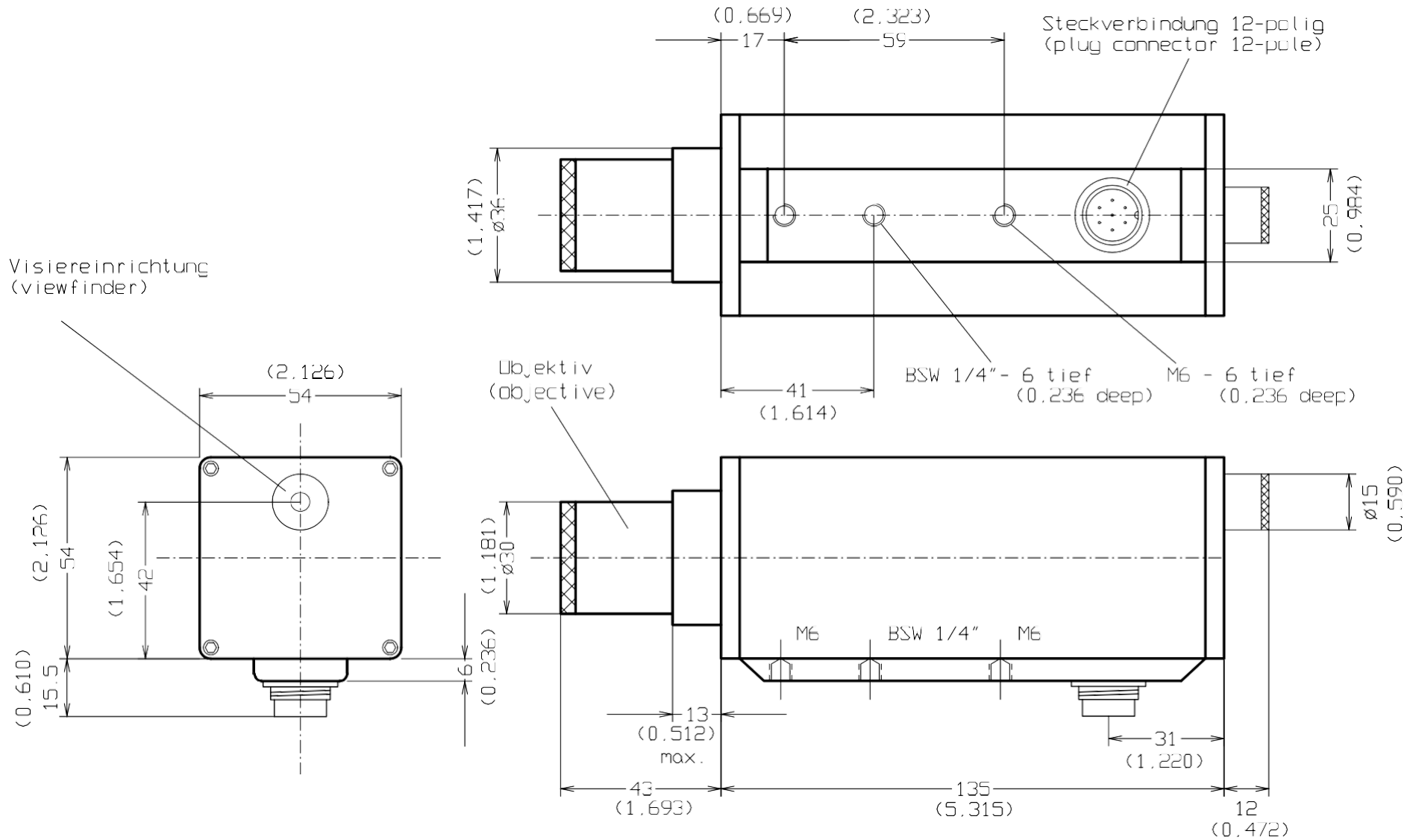

(xxx) - Maße in Zoll
(dimensions in inch)

				Maßstab 1:1	
				STANDARDGEHÄUSE (standard case)	
				KTRD 1000-2 Stecker 90° (connector 90°)	
				Visiereinrichtung (viewfinder)	
				100207	
				Blatt	
				Bl.	
Zust.	Anderung	Datum	Name		