

Non-Contact Temperature Measurement

DIGITAL – INFRARED – PYROMETER

Temperature range -20 to 1000°C (-4 - 1832°F)

**Temperature control during production process
compact units – Infrared – measuring transducer and electronic process
unit in one case with light beam aiming device
or optical viewfinder, focusable optic,
serial interface, limit output**

Series KTRD 1105



Infrared – pyrometer can also assist you to monitor your heating processes, ensuring a uniform standard of quality for your products.

leaflet KTRD 1105

Dr. Georg Maurer GmbH
-Optoelektronik-

GRUBATEC



MESS- UND REGELTECHNIK

Grubatec AG
Wölferstrasse 5
4414 Füllinsdorf
Telefon: +41 (0)55 617 00 80
Telefax: +41 (0)55 617 00 81
www.grubatec.ch
sales@grubatec.ch

Infrared-Digital-Pyrometer Series KTRD 1105

More than 60 years experience in the area of non-contact temperature measurement and permanently development of the pyrometers makes it possible to offer you a complete program of field tested units..
Mainly for **fast warming processes contactless temperature measurement** is suitable.

The **series KTRD 1105** are **digital part radiation pyrometer** with vario-objective in compact structure likewise suitable for industry, research and laboratory.

With the integrated light beam aiming device (green LED or Laser) resp. viewfinder an adjusting of the pyrometer to the measuring object is very easy.

The temperature linear analog output signal 0/4 up to 20 mA is available for measuring- and controlling purposes.

The simultaneous using of the serial interface with the software IR-LOG enables the data detection, graphical representation and the parameter settings of the pyrometer.

Examples for applications:

ceramics, rubber, paper, wood, food, asphalt, building material, electronic components, plastics, plastic deep-drawing, lacquering drying, drying process etc

Technical datas:	KTRD 1105-1		KTRD 1105-2
Unit types	KTRD 1105-1		KTRD 1105-2
Target marking	light beam aiming device green LED or laser		viewfinder
Temp. measuring ranges:	MR 1: 0 - 100°C 32 - 212°F	MR 2: 0 - 500°C 32 - 932°F	MR 3: 100 - 1000°C 212 - 1832°F
Response time (t90)	<100 ms		
Spectral range	8-14 μm		
Measuring uncertainty	0,5% of meas.value in °C ± 1°C (ε = 1, T _{amb.} = 23°C, T ₉₅ = 1s)		
Reproducibility	0,3% of meas.value in °C ± 1°C (ε = 1, T _{amb.} = 23°C, T ₉₅ = 1s)		
Emission factor ε	100 - 10 % adjustable at the unit or through interface		
Analog output	0 - 20 mA or 4 - 20 mA , load max. 500R		
Part measuring ranges:	free adjustable within the measuring range		
Resolution	< 0,1% analog output, < 0,1°C at interface		
1 limit output (open coll.)	24 V DC / max. 100 mA		
Max.reading memory	max.memory, double memory,adjustable time and threshold value, erasing after time, external contact, by software, after new meas.part		
Interface	RS 232 isolated ± 50 V or RS 485 isolated 2500VRMS options: PROFIBUS, PROFINET, Ethernet, EtherCAT, USB 2.0		
Software IR-LOG	data recording, graph.representation, setting of pyrometer parameters		
adjustable parameter with Software IR-LOG	emissionfactor,switching output,analog output, part meas.range, °C/°F, max.memory, average value, light beam aiming device switchable		
Objectives	for accommodation to the measuring application an extensive selection of objectives are available		
Working temperature	pyrometer 0 - 50°C (32-122°F)		
Stock temperature	- 10°C - + 70°C (14-158°F)		
Temperature sensitivity	0,05 % / °C		
Humidity tolerance	35 - 85 % RF (non condensing)		
Operating voltage	24 V DC ± 10 % or 18 V AC ± 10 % < 160 mA		
Unit connection	12-pole plug-connector		
Dimensions: H / W / D	54 x 54 x 147 mm (2,13 x 2,13 x 5,79 inch) ALU-case		
Weight	0,6 kg (1,32 lbs)		
Protection grade	IP 65		
Option	built in digital display		

mechanical assembly	electrical assembly		
Execution in cooling case	AED 1012	electr.process unit	digital display (built in-execution)
Blowing device	AED 1012-C	PID controller	connection cable 12-pole
Mirror 90°	AED 1012-PC	Program controller	line scanner SC 1000 / SC 1012
Mounting parts	power supply 100-270VAC - 24 VDC	PC-Box (USB – connection set)	

Optic tables for KTRD 1105

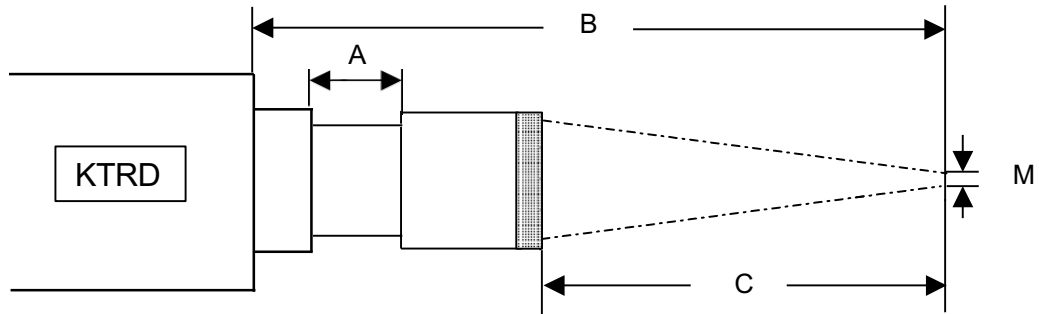

Optic-type	: IR 1040		
Lens	: f=1,5" $\varnothing=1"$ (12/04)		
Meas. aperture	: 1,0 mm \varnothing		
Meas. distance from casing of meas. head B / mm	Meas. distance from optic front edge C / mm	Optic extension A / mm	Target size M / mm=d
150	116,0	13	3,0
200	170,8	8,2	4,0
300	273,9	5,1	6,8
400	375,2	3,8	9,5
500	476,5	2,5	12,2
600	577,3	1,7	15,5
700	677,7	1,3	17,3
800	778,2	0,8	20,6
900	878,6	0,4	24,2
1000	979,0	0	29,4

Optic-type	: IR 1060-N		
Lens	: f 2,5" $\varnothing=1"$ (01/06)		
Meas. aperture	: 1,0 mm \varnothing		
Meas. distance from casing of meas. head B / mm	Meas. distance from optic front edge C / mm	Optic extension A / mm	Target size M / mm=d
300	244	13	3,4
350	298	9,0	4,0
400	350,6	6,4	4,9
450	402,3	4,7	6,0
500	454	3,0	6,6
550	505	2,0	7,7
600	556	1,0	8,5
650	607	0	9,3
700	657	0	10
900	857	0	22,2

Optic-type	: IR 1060-T		
Lens	: f 2,5" $\varnothing=1"$		
Meas. aperture	: 1,0 mm \varnothing		
Meas. distance from casing of meas. head B / mm	Meas. distance from optic front edge C / mm	Optic extension A / mm	Target size M / mm=d
440	384	13	5,4
500	444,8	12,2	6,1
600	547,3	9,7	7,8
700	649,1	7,9	8,6
800	750,2	6,8	10,4
900	851	6	12
1000	951,3	5,7	13,6
1500	1452,2	4,8	21
2000	1952,6	4,4	29,8
3000	2954,5	2,5	42
4000	3955,6	1,4	60
5000	4956	1,0	75

Optic-type	: IR 1040-M		
Lens	: f 1,5" $\varnothing=1"$		
Meas. aperture	: 1,0 mm \varnothing		
Meas. distance from casing of meas. head B / mm	Meas. distance from optic front edge C / mm	Optic extension A / mm	Target size M / mm=d
103	60	0	1,5

Target=98 % of beam density of the surface

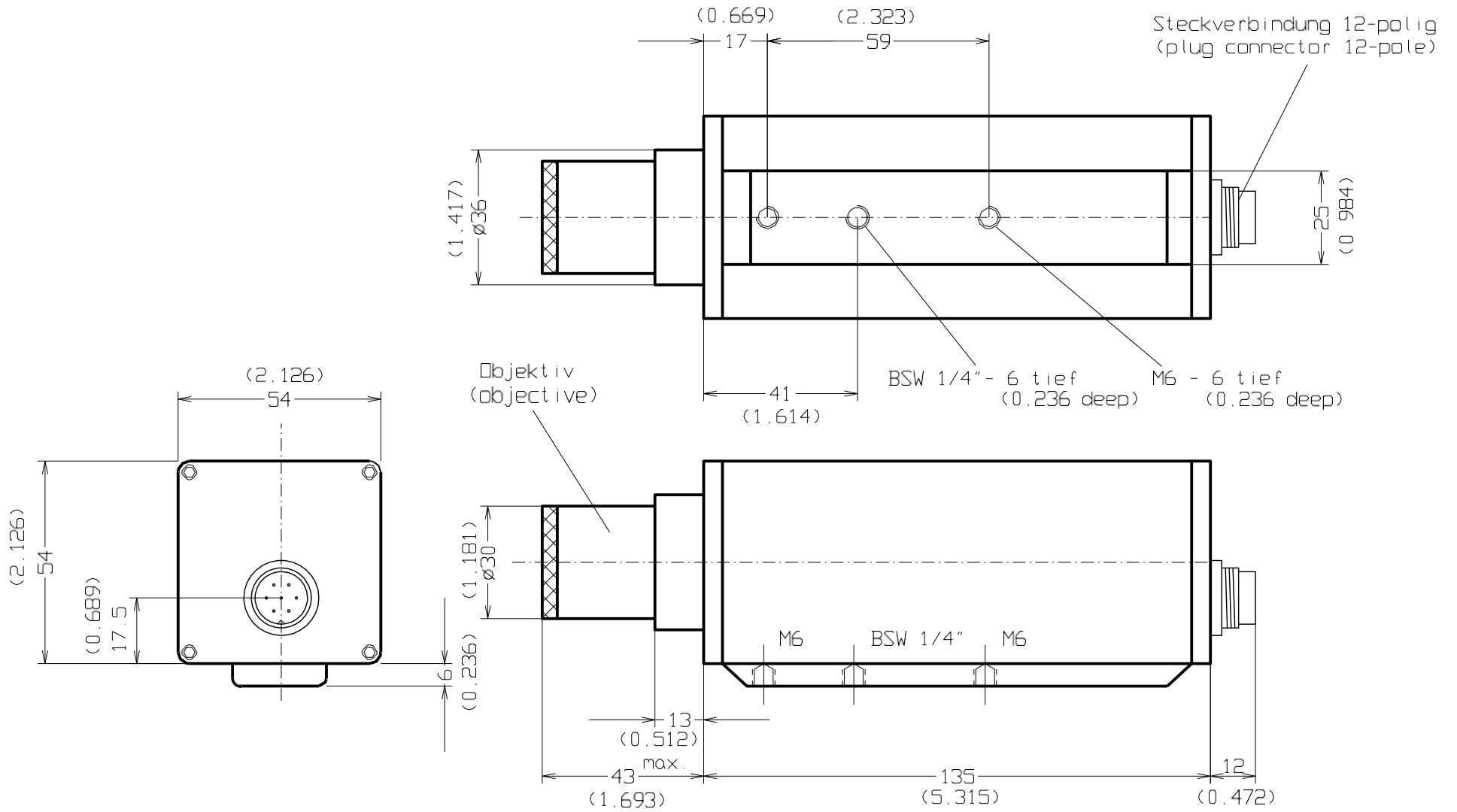

(xxx) - Maße in Zoll
(dimensions in inch)

				Maßstab 1:1	
				Fa. Dr. Maurer GmbH	
				STANDARDGEHÄUSE (standard case)	
				KTRD 100 0-1	
				100205	
				Blatt	
				Bl	
Zust	Anderung	Datum	Name		

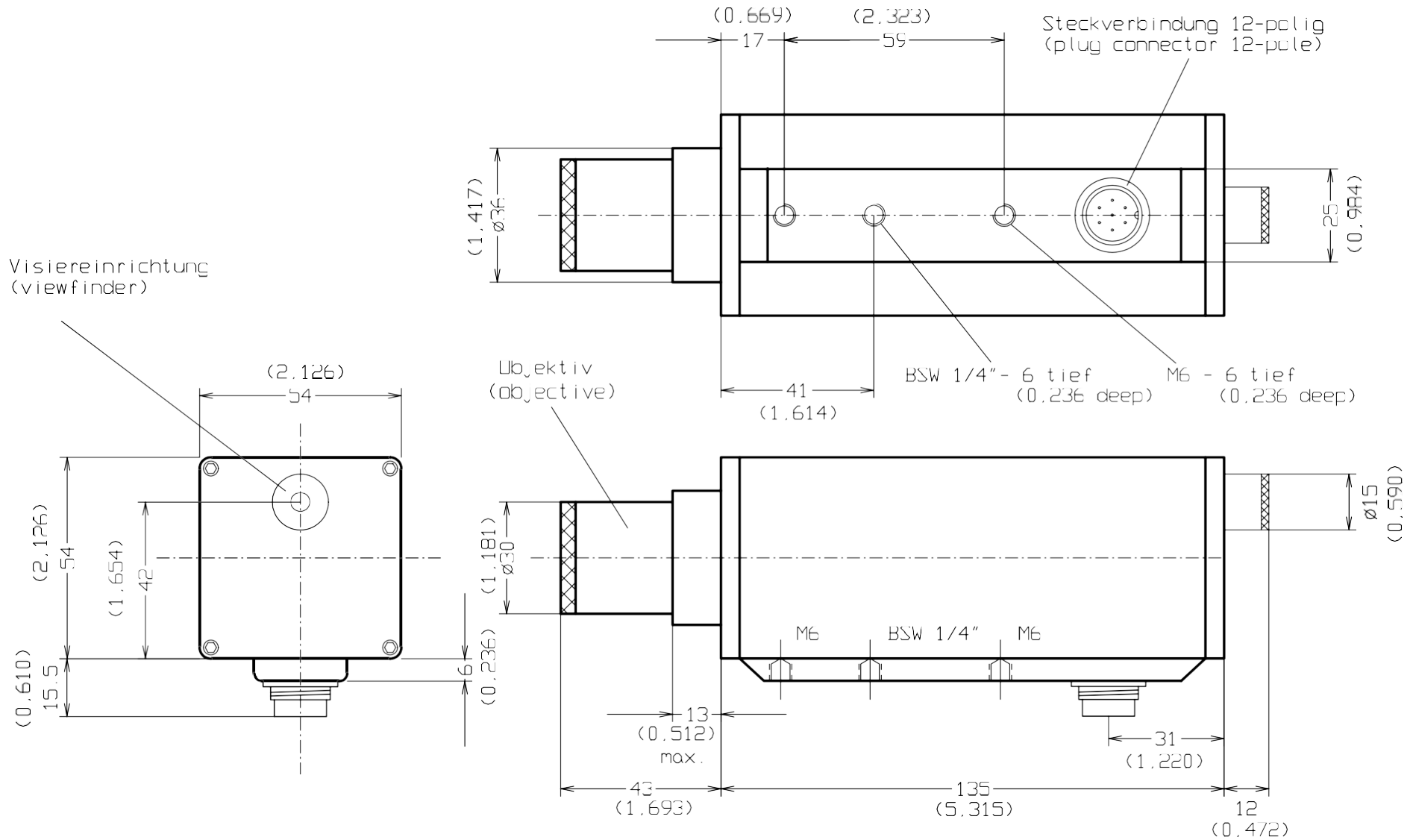

(xxx) - Maße in Zoll
(dimensions in inch)

				Maßstab 1:1	
				STANDARDGEHÄUSE (standard case)	
				KTRD 1000-2 Stecker 90° (connector 90°)	
				Visiereinrichtung (viewfinder)	
				100207	
				Blatt	
				Bl	
Zust	Anderung	Datum	Name		