

Non-Contact Temperature Measurement

DIGITAL – INFRARED – PYROMETER

Temperature range 600 to 2500°C (1112 – 4532°F)

**Temperature control during production process
compact unit – with light beam aiming device**

- focusable optic
- RS 232 or RS 485 interface
- limit output (open collector)

Series KTRD 4085-1



figure approx. M 1:1

Infrared – pyrometer can also assist you to monitor your heating processes, ensuring a uniform standard of quality for your products.

leaflet KTRD 4085-1

Dr. Georg Maurer GmbH
-Optoelektronik-

GRUBATEC



Grubatec AG
Wölferstrasse 5
4414 Füllinsdorf
Telefon: +41 (0)55 617 00 80
Telefax: +41 (0)55 617 00 81
www.grubatec.ch
sales@grubatec.ch

Digital Infrared-Pyrometer Series KTRD 4085-1

60 years experiences and digital technology makes it possible!

A pyrometer – as small as a cigarette-box – but powerful like a big one.

- light beam aiming device with LED
- focusable optic
- emissivity adjustable at the unit
- analog-and digital output
- 1 adjustable limit output (open collector)
- software IR-LOG

Through the serial interface additional parameter functions are possible:

analog output: 0 – 20 / 4 – 20 mA switchable

zoom range within measuring range

emissivity: 100,00 – 10,00 %

average: arithmetical or sliding

maximum value storage: storage modes and erase functions par ex. automatically with the next measuring object

Examples of applications:

steel, iron, non-ferrous metal, wires, ceramics, glass feeder, glass tub, glass arching, hardening, rolling, induction heating, brazing, forging, welding, transforming, vacuum furnace

unit type	target marking
KTRD 4085-1	light beam aiming device LED green

Temperature measuring range

- linear -

No.	temperature range short:
1	600 - 1200°C (1112 - 2192°F)
2	650 - 1300°C (1202 - 2372°F)
3	700 - 1400°C (1292 - 2552°F)
4	750 - 1500°C (1382 - 2732°F)
5	800 - 1700°C (1472 - 3092°F)
6	900 - 2000°C (1652 - 3632°F)

No.	temperature range long:
7	600 - 1600°C (1112 - 2912°F)
8	700 - 2000°C (1292 - 3632°F)
9	850 - 2500°C (1562 - 4532°F)

special measuring ranges
on request

Technical datas:

Spectral response	0,85 – 1,1 µm
Response time	1 ms
Accuracy	0,5 % ± 1°C
Reproducibility	1 ‰
Emissivity	100 - 10 %
Operating temperature	0 - 60°C (32 – 140°F)
Storage temperature	- 10°C - + 70°C (14 – 158°F)
Temperature-sensitivity	0,01 % / °C
Humidity tolerance	35 - 85 % RF
Analog output temp.linear	0 – 20 mA or 4 – 20 mA
1 Limit output (open coll.)	24 V 100 mA
Digital output	RS 232 ± 50 V isolated or RS 485 ± 70 V isolated
Operating voltage	DC 24 V ± 10 %
Supply current	< 100 mA
Unit connection	8-pole plug connector
Dimensions H / W / D	65 x 30 x 80 mm (2,56 x 1,18 x 3,15 inch)
Weight	0,15 kg (0,33 lbs)
Protection class	IP 65

Objectives: For optimum accomodation to the measuring application an objective with focusing is available.

Adjusting range 100 mm to infinite, distance ratio: D = 85

Calculation of target size: $\frac{\text{focusing distance } M \text{ mm}}{D = 85}$ par ex. $\frac{M = 100 \text{ mm}}{D = 85} = 1,18 \text{ } \varnothing$

electrical assembly		mechanical assembly	
AED 1012	electronic process unit	PC-Box (USB – connection set)	execution in cooling case
AED 1012-C	PID controller	USB-RS232 – 8-pol connector	blowing devices
AED 1012-C	Program controller	USB-RS485 – 8-pol connector	mirror 90°
power supply	100-270VAC - 24 VDC	connection cable 8-pole	mounting parts

Connection diagram KTRD 4000

8-pole plug-connector – cable with free ends



cable socket straight



cable socket 90°

female 8-pole PIN	color	function
1	white	⊥ 24VDC / ⊥ - output 0-20mA / 4-20mA ** storage reset or aiming device (button), limit value
2	brown	+ 24 VDC
3	green	+ output 0-20mA
4	yellow	external controlling input selective for storage reset or aiming device (button)
5	grey	limit value (open collector) resp. min. intensity
6	pink	RS 232 TXD (from PC 9-pole SUB-D PIN 2)
7	blue	RS 232 RXD (from PC 9-pole SUB-D PIN 3)
8	red	RS 232 GND (from PC 9-pole SUB-D PIN 5)
housing	black (screen)	PE (earth)
		** ⊥ central ground

8-pole plug-connector – 15-pole SUB-D (AE 10XX)

contact arrangement
(view on solder termination)

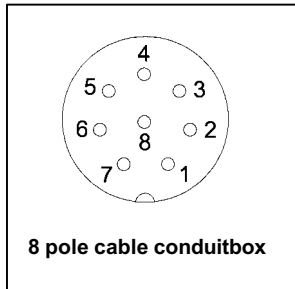

female 8-pole PIN	color	function	15-pole male Sub-D PIN
1	white	⊥ 24VDC / ⊥ - output 0-20mA / 4-20mA ** storage reset or aiming device (button), limit value	connection to PIN 13 4
2	brown	+ 24 VDC	1
3	green	+ output 0-20mA	8
4	yellow	external controlling input selective for storage reset or aiming device (button)	12
5	grey	limit value (open collector) resp. min. intensity	2
6	pink	RS 232 TXD (from PC 9-pole SUB-D PIN 2)	9
7	blue	RS 232 RXD (from PC 9-pole SUB-D PIN 3)	10
8	red	RS 232 GND (from PC 9-pole SUB-D PIN 5)	11
housing	black (screen)	PE (earth)	15
			connection to PIN 4 13
		** ⊥ central ground	

mounting stud standard for KTRD 4000-series

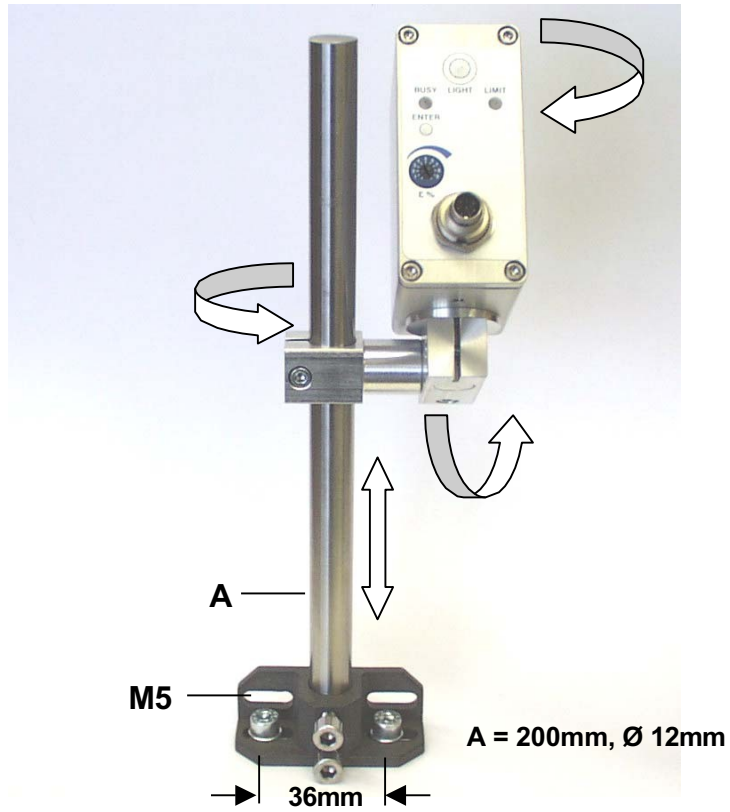

mounting stud universal for KTRD 4000-series

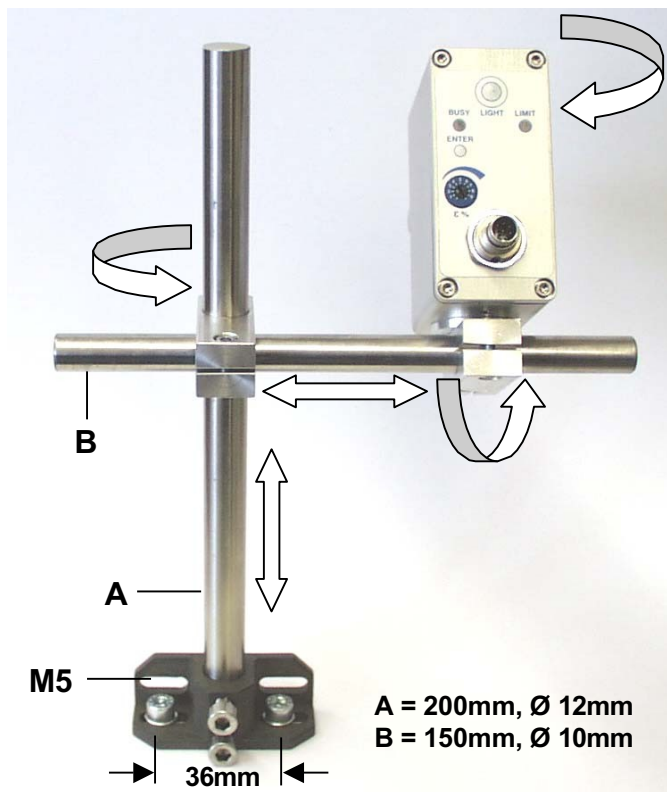

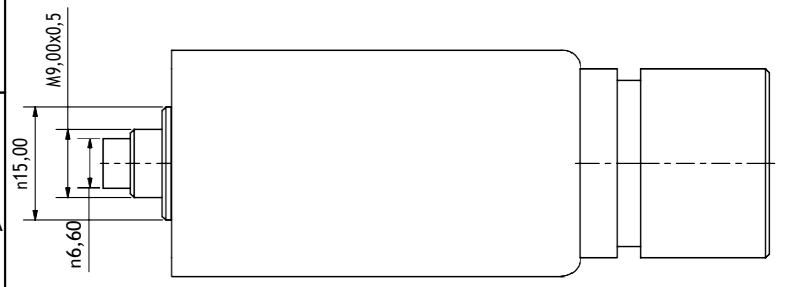
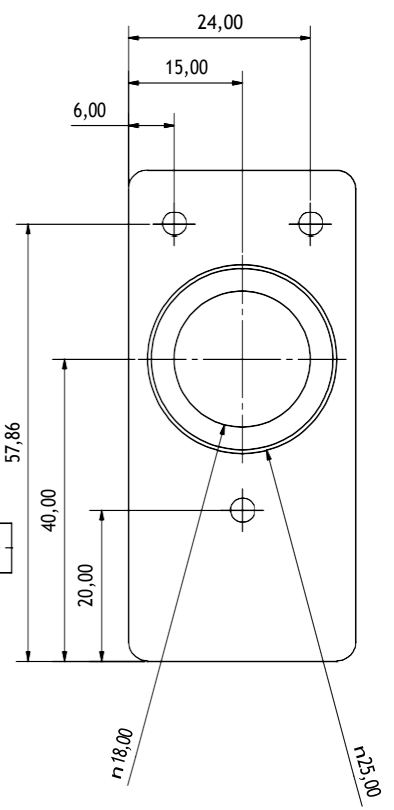
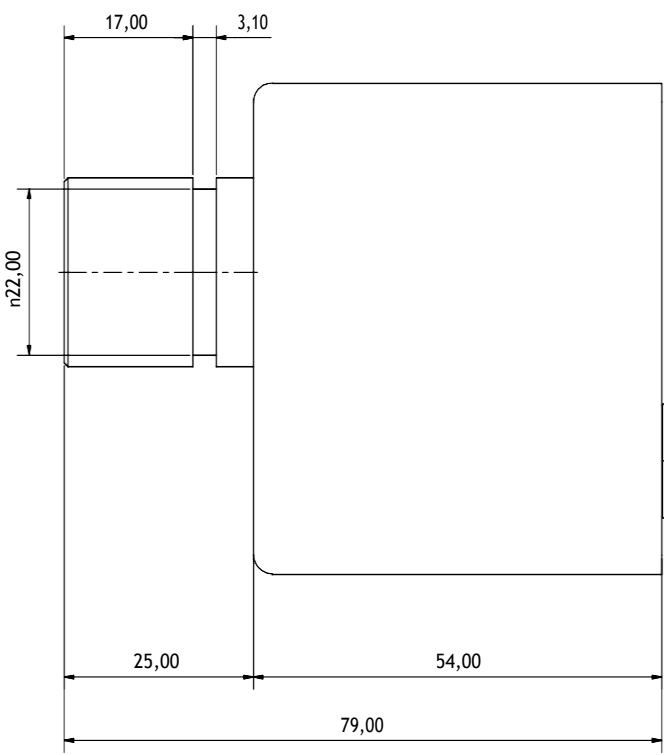
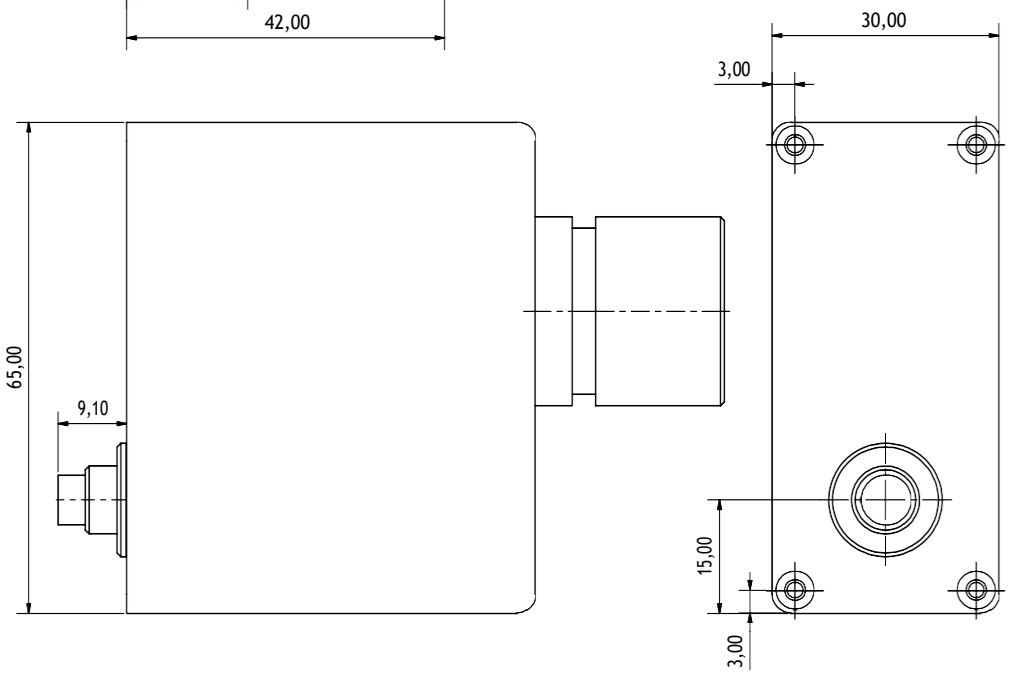
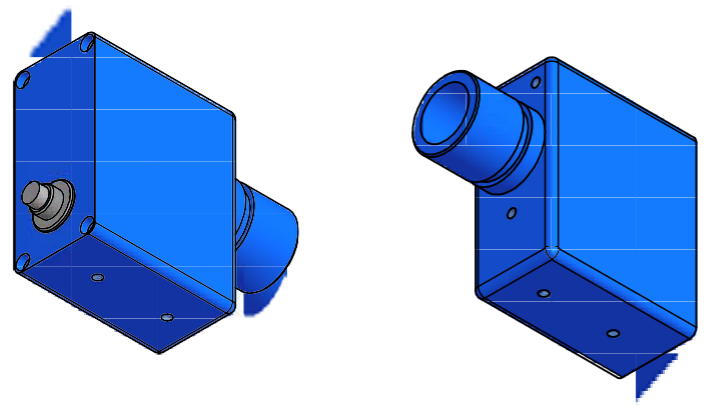
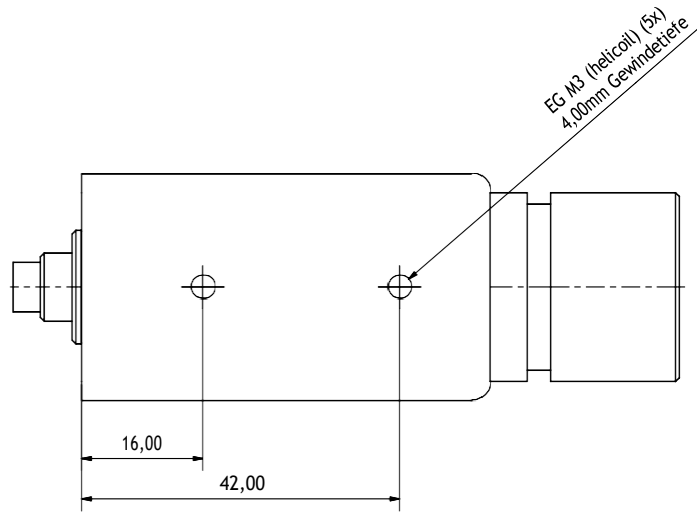

Dr. Maurer		Tol. +/-0,1mm		AlCuMgPb	
KTR 4000		Date	Name	Gehäuse KTR 4000	
		gezeichnet	02.01.2008	CME	
		geprüft	02.01.2008	CME	
				Optoelektronik	060902+060905
				info@maurer-ir.de	1
Status	Änderung	Datum	Name		