

Non-Contact Temperature Measurement

DIGITAL – INFRARED – FIBER OPTIC – PYROMETER

Temperature range 300 to 1500°C (572 – 2732°F)

**Temperature control during production process
compact unit – with light beam aiming device**

- fiber optic
- RS 232 or RS 485 interface
- limit output (open collector)

Series KTRD 4475-1



figure approx. M 1:1

Infrared – pyrometer can also assist you to monitor your heating processes, ensuring a uniform standard of quality for your products.

leaflet KTRD 4475-1

Dr. Georg Maurer GmbH
-Optoelektronik-

GRUBATEC



MESS- UND REGELTECHNIK

Grubatec AG
Wölferstrasse 5
4414 Füllinsdorf
Telefon: +41 (0)55 617 00 80
Telefax: +41 (0)55 617 00 81
www.grubatec.ch
sales@grubatec.ch

Digital Infrared- Fiber Optic-Pyrometer Series KTRD 4475-1

60 years experiences and digital technology makes it possible!

A pyrometer – as small as a cigarette-box – but powerful like a big one.

- fiber optic
- light beam aiming device with a green LED for target marking
- emissivity adjustable at the unit
- analog- and digital output
- 1 adjustable limit output (open collector)
- software IR-LOG

Through the serial interface additional parameter functions are possible:

analog output: 0 – 20 / 4 – 20 mA switchable

zoom range within measuring range

emissivity: 100,00 – 10,00 %

average: arithmetical or sliding

maximum value storage: storage modes and erase functions par ex. automatically with the next measuring object

Examples of applications:

steel, iron, non-ferrous metal, wires, ceramics, hardening, rolling, induction heating, soldering, brazing, forging, welding, transforming, vacuum furnace

Temperature measuring range

- linear –

No.	temperature range short:
1	300 - 800°C (572 – 1472°F)
2	350 - 900°C (662 – 1652°F)
3	400 - 1000°C (752 – 1832°F)
4	500 - 1200°C (932 – 2192°F)

No.	temperature range long:
5	300 - 1300°C (572 - 2372°F)
6	400 - 1500°C (752 - 2732°F)

special measuring ranges
on request

Technical datas:

Spectral response	1,45 - 1,7 μm
Response time	1 ms
Accuracy	0,5 % ± 1°C
Reproducibility	1 ‰
Emissivity	100 - 10 %
Operating temperature	0 - 60°C (32 – 140°F)
Storage temperature	- 10°C - + 70°C (14 – 158°F)
Temperature-sensitivity	0,01 % / °C
Humidity tolerance	35 - 85 % RF
Analog output temp.linear	0 – 20 mA or 4 – 20 mA
1 Limit output (open coll.)	24 V 100 mA
Digital output	RS 232 ± 50 V isolated or RS 485 ± 70 V isolated
Operating voltage	DC 24 V ± 10 %
Supply current	< 100 mA
Unit connection	8-pole plug connector
Dimensions H / W / D	65 x 30 x 80 mm (2,56 x 1,18 x 3,15 inch)
Weight	0,15 kg (0,33 lbs)
Protection class	IP 65

Fiber optic: Type GM-L, length 500 mm in metal hose

ambient temperature max. 150°C, bend radius min. 100 mm

	fiber optic	Type GM-L	500 mm	∅ 0,6 mm fiber	temperature range no.
	fiber optic	Type GM-L	500 mm	∅ 0,4 mm fiber	temperature range no. 1 + 2 + 5
	fiber optic	Type GM-L	500 mm	∅ 0,2 mm fiber	temperature range no. 3 + 4 + 6

(other length and fiber on request)

Objectives: For accomodation to the measuring application are several objectives and optic systems available.
(see datasheet)

electrical assembly		mechanical assembly	
AED 1012	electronic process unit	PC-Box (USB – connection set)	execution in cooling case
AED 1012-C	PID controller	USB-RS232 – 8-pol connector	blowing devices
AED 1012-C	Program controller	USB-RS485 – 8-pol connector	mirror 90°
power supply	100-270VAC - 24 VDC	connection cable 8-pole	mounting parts

objective for fiber optic pyrometer

**fix-focus
M12x1**

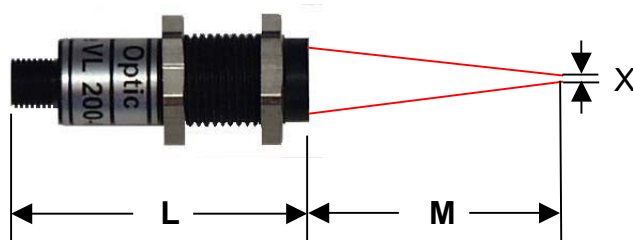

optic type	M / mm	L / mm	target size X Ø / mm	
VL 50-M12	50	38	fiber 0,2mm	0,7mm
			fiber 0,4mm	1,4mm
			fiber 0,6mm	2,0mm
VL 100-M12	100	40	fiber 0,2mm	1,0mm
			fiber 0,4mm	2,0mm
			fiber 0,6mm	3,0mm
VL 150-M12	150	38	fiber 0,2mm	1,4mm
			fiber 0,4mm	2,7mm
			fiber 0,6mm	4,0mm
VL 200-M12	200	38	fiber 0,2mm	2,0mm
			fiber 0,4mm	4,0mm
			fiber 0,6mm	6,0mm

**vario-focus
Ø 18mm**

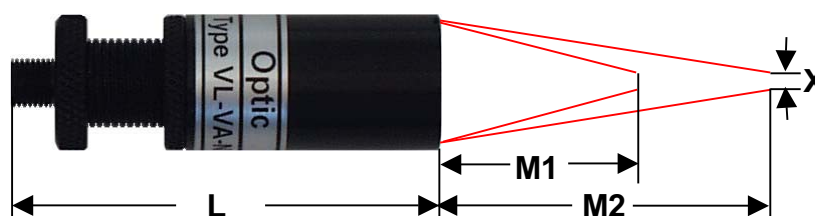

target size X: $\frac{\text{focusing distance M mm}}{\text{distance ratio D}}$ par ex. $\frac{M = 150\text{mm}}{D = 75} = 2,00 \text{ mm } \varnothing$

optic type	M1 / mm	M2 / mm	L / mm	distance ratio D	
VL-VA-N	65	160	46 - 56	fiber 0,2mm	138
				fiber 0,4mm	69
				fiber 0,6mm	46
VL-VA-T	100	5000	46 - 56	fiber 0,2mm	150
				fiber 0,4mm	75
				fiber 0,6mm	50

Connection diagram KTRD 4000

8-pole plug-connector – cable with free ends



cable socket straight



cable socket 90°

female 8-pole PIN	color	function
1	white	⊥ 24VDC / ⊥ - output 0-20mA / 4-20mA ** storage reset or aiming device (button), limit value
2	brown	+ 24 VDC
3	green	+ output 0-20mA
4	yellow	external controlling input selective for storage reset or aiming device (button)
5	grey	limit value (open collector) resp. min. intensity
6	pink	RS 232 TXD (from PC 9-pole SUB-D PIN 2)
7	blue	RS 232 RXD (from PC 9-pole SUB-D PIN 3)
8	red	RS 232 GND (from PC 9-pole SUB-D PIN 5)
housing	black (screen)	PE (earth)
		** ⊥ central ground

8-pole plug-connector – 15-pole SUB-D (AE 10XX)

contact arrangement
(view on solder termination)

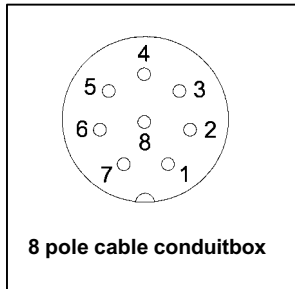

female 8-pole PIN	color	function	15-pole male Sub-D PIN
1	white	⊥ 24VDC / ⊥ - output 0-20mA / 4-20mA ** storage reset or aiming device (button), limit value	connection to PIN 13 4
2	brown	+ 24 VDC	1
3	green	+ output 0-20mA	8
4	yellow	external controlling input selective for storage reset or aiming device (button)	12
5	grey	limit value (open collector) resp. min. intensity	2
6	pink	RS 232 TXD (from PC 9-pole SUB-D PIN 2)	9
7	blue	RS 232 RXD (from PC 9-pole SUB-D PIN 3)	10
8	red	RS 232 GND (from PC 9-pole SUB-D PIN 5)	11
housing	black (screen)	PE (earth)	15
			connection to PIN 4 13
		** ⊥ central ground	

mounting stud standard for KTRD 4400-series objective M12

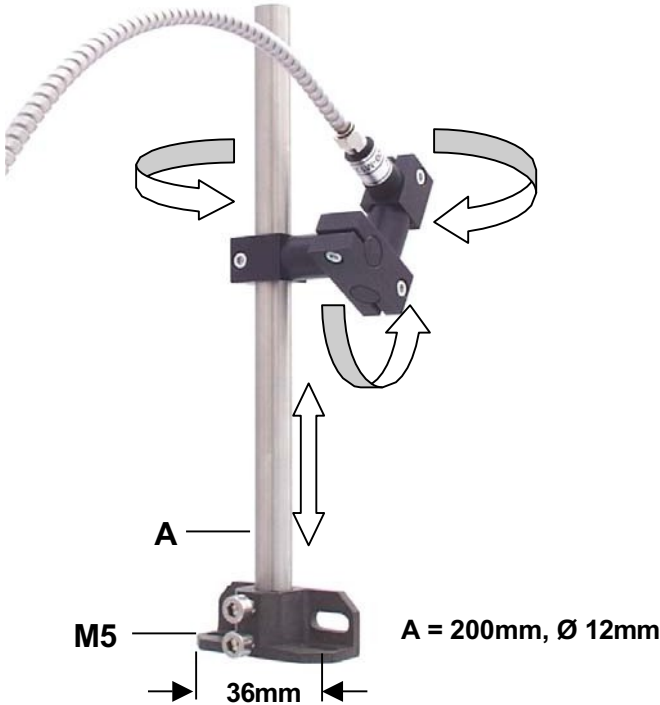

Art.Nr. 118-2004

mounting stud universal for KTRD 4400-series objective M12

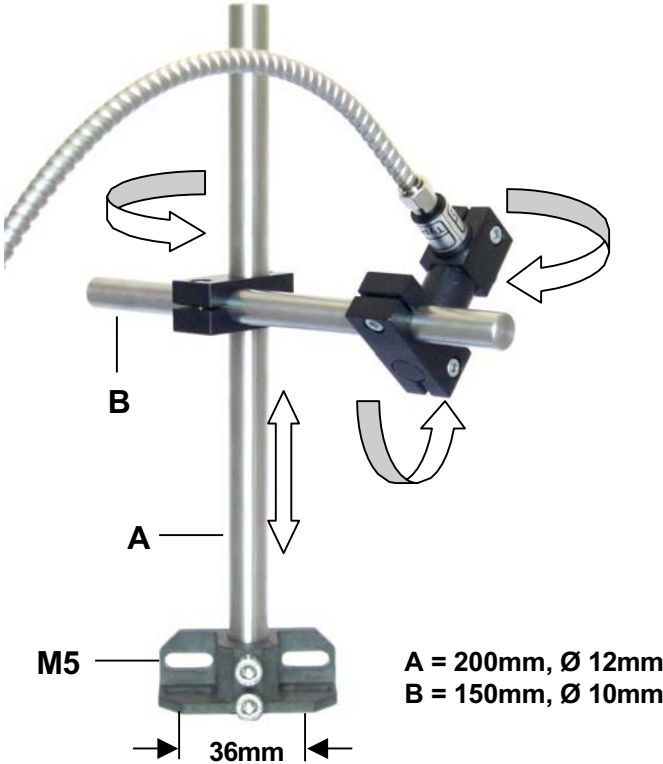

Art.Nr. 118-2006

mounting stud standard for KTRD 4400-series objective Ø 18mm

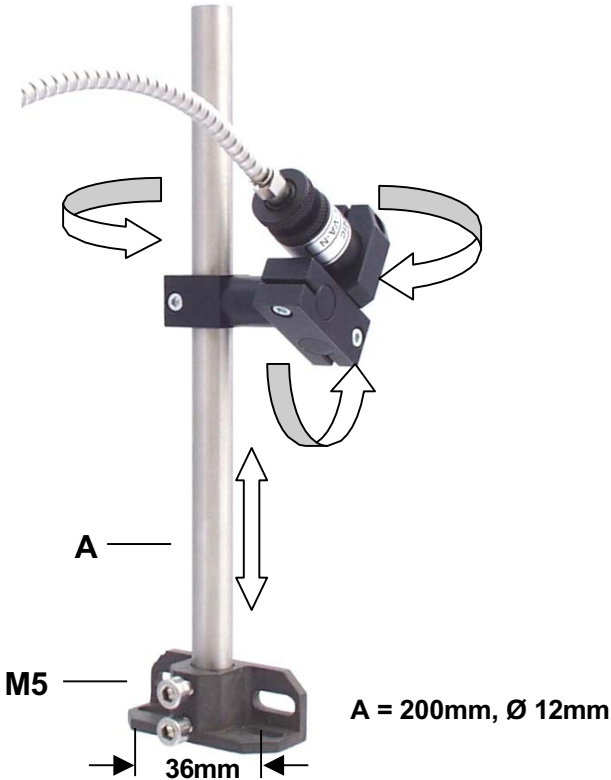

Art Nr. 118-2003

mounting stud universal for KTRD 4400-series objective Ø 18mm

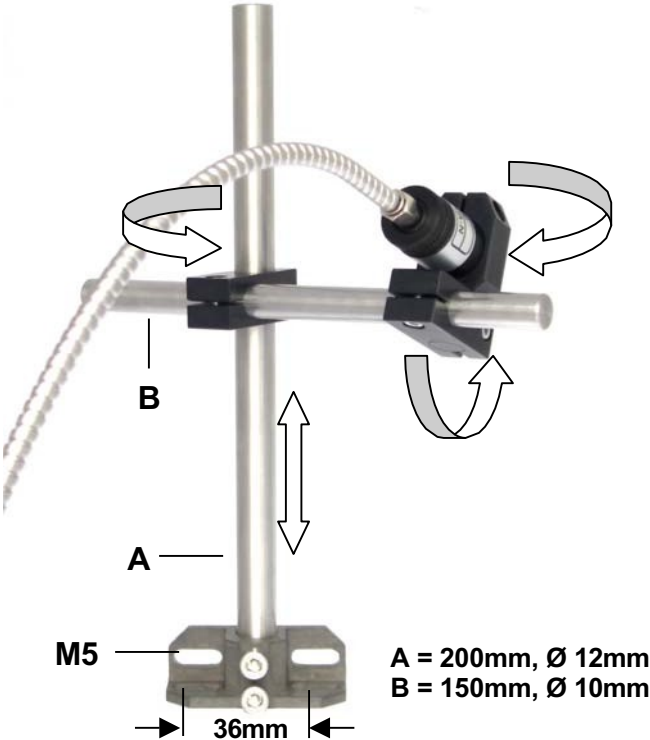

Art Nr. 118-2005

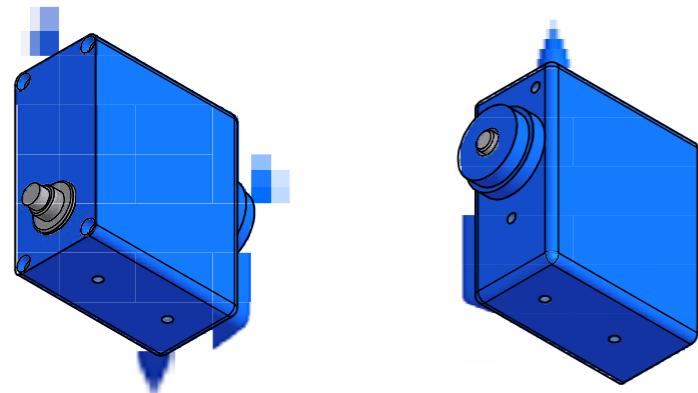

EG M3 (helicoil) (5x)
4,00mm Gewindetiefe

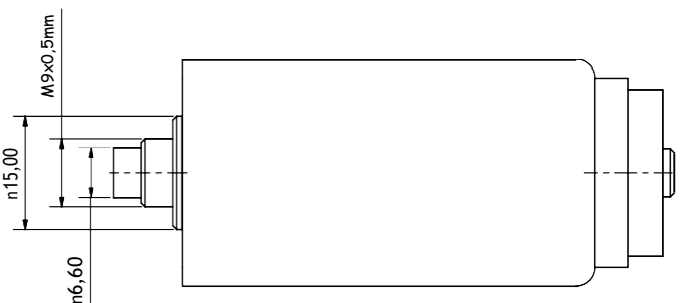
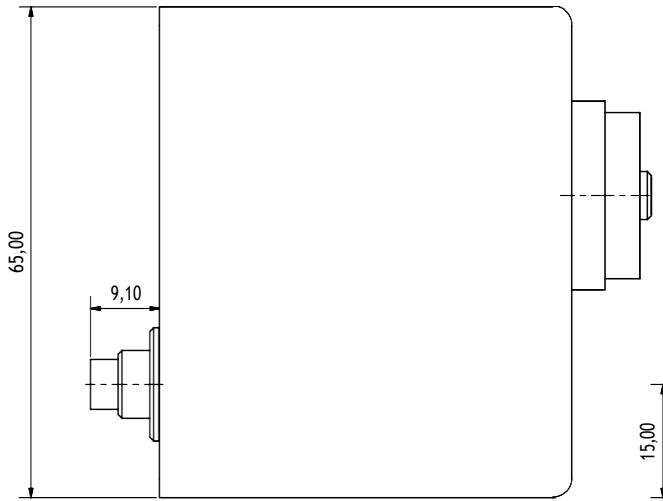
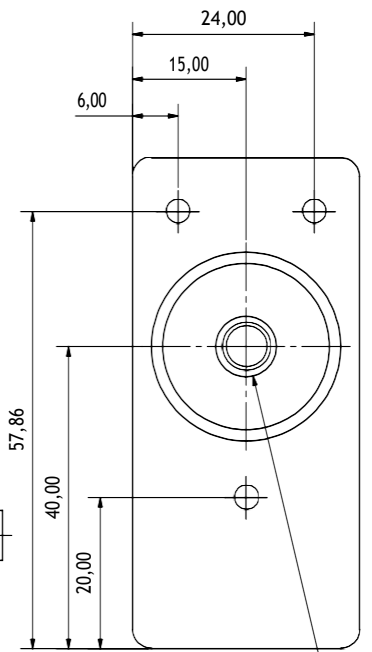
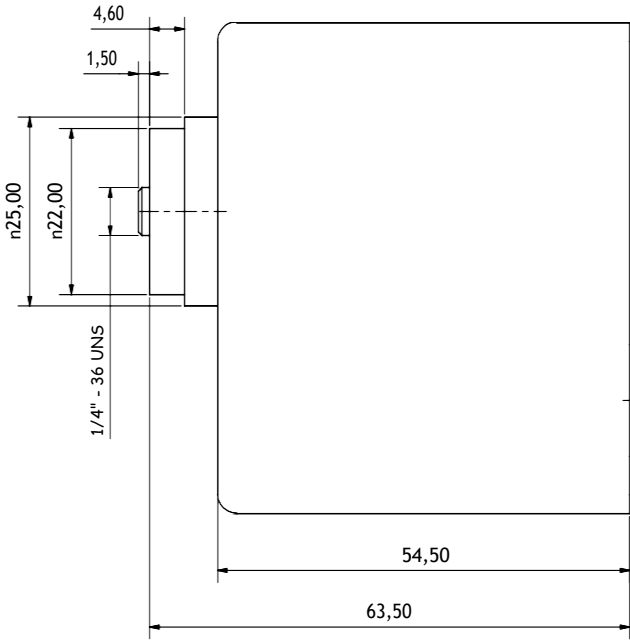
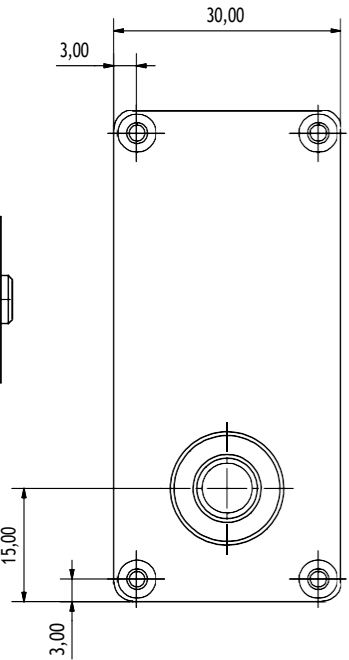
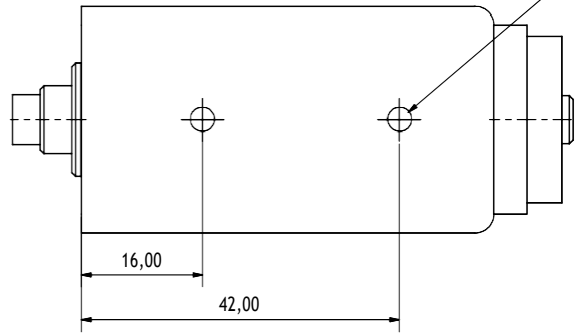

Dr. Maurer		Tol. +/-0,1mm		AlCuMgPb	
KTR 4400					
		Date	Name		
		02.08.2008	CME		
		02.08.2008	CME	Gehäuse KTR 4400	
		Optoelektronik			1
		info@maurer-ir.de			
Status	Änderung	Datum	Name		